

INSTRUCTION  
SHEET

1/48

## Adlertag

## Bf 110 UNITS IN THE BATTLE OF BRITAIN

Jan Bobek

The Battle of Britain is one of a list of legendary milestones that defined World War Two, while, at the same time, being one that played out exclusively in the air. As far as the RAF is concerned, it began on July 10th, 1940 and lasted to the end of October of the same year. Its multi-national character was underscored by the fact that thirteen other nations had participated on Britain's behalf. As far as the Germans are concerned, the battle began just shy of a month later, and ended with the first failure since the war began.

To grasp the circumstances surrounding the Battle of Britain, it is necessary to remind ourselves of some important facts emanating from the Battle of France, which itself went from the 10th of April to June 25th, 1940. During this time period, German pilots and anti-aircraft gun crews claimed a total of 2,379 enemy aircraft shot down, with another 1,850 destroyed on the ground. However, the Germans lost 1,401 aircraft, with a further 672 damaged. Pilots flying the Messerschmitt Bf 110 themselves lost 216 aircraft destroyed or damaged. A total of 110 airmen lost their lives, and 47 were wounded. A further 31 ended as prisoners of war. The actual total of captured airmen was much higher, and prior to the fall of France, the Allies were in talks regarding the transfer of all prisoners taken on French soil to Canada. That, however, did not happen, and as a result, at the end of June and beginning of July, several hundred well trained and experienced pilots were returned to Germany, instead of making their way across the Atlantic. Among them were such notable figures as Walter Grabmann, Kommodore of ZG 76.

The Wehrmacht defined its priorities in the war against England at the end of June, with three possible outcomes: 1) initiating a blockade that would cut off the United Kingdom from the rest of the world, 2) attacks evoking terror within the civilian population, and 3) an invasion with the goal of occupying the United Kingdom. Assets would be focused on the defeat of the RAF and to gain, and maintain, air superiority, which would make the invasion possible.

Fighter units of the Luftwaffe needed to replace their losses in terms of men and material after the French campaign. There was a realization that the needed infrastructure was not in place in northwestern France to support the planned attack on the United Kingdom. The building of airfields through July and into August, which was a critical period for the harvest, was naturally met with protests from French farmers.

Three Luftflotte were employed for the attack on Great Britain, each tasked with targets in specific areas of the island. Luftflotte 5 (with no fighter component) was based in Scandinavia and focused on action over eastern Scotland. With bases in Western Europe, Luftflotte 2 concentrated their efforts on eastern England and Luftflotte 3 was to focus on western England and Wales.

Fighter wings armed with twin engined aircraft (Zerstörerengeschwader, a 'destroyer' wing) during early summer of 1940 were equipped with standard Bf 110C versions, as well as long range BF 110D versions. A half dozen Bf 110C-6, equipped with a 30mm cannon, were undergoing operational testing.

Bf 110C-3s were equipped with a pair of 20mm MG FF/M cannon, instead of the MG FF with a slower rate of fire.

To facilitate the Bf 110's use as a fighter-bomber, German aircraft manufacturers were producing the D-3 (with extended fuselage for dinghy stowage), C-4/B with paired ETC 250 bomb racks and the C-7, with paired ETC 500 bomb racks. Another modification was in the installation of the DB 601N engine, rated at 1175k. These engines were normally fitted to above mentioned fighter bomber versions. Aircraft equipped with DB 601N for recon missions were designated Bf 110C-5/N. This engine required the use of C3 100 octane fuel.

Individual Zerstörerengeschwader units were attached to the aforementioned Luftflotte 2 and 3. For their organizational elements, and their co-ordination within the system, each Luftflotte had a command hub directing fighter ops (Jagdfliegerführer, shortened to Jafü), and their designation number corresponded to that of the Luftflotte under which they fell.

The commander of Jafü 2 was a First World War fighter pilot, GenMaj. Kurt-Bertram von Döring, and he was responsible not only for Bf 109 units, but also their colleagues with Bf 110s of Stab, I., II., III./ZG 26 and Stab and III./ZG 76 (former II./ZG 1). Besides that, Luftflotte 2 also had under it II. Fliegerkorps, which included Erprobungsgruppe 210, tasked with the testing of aircraft in the role of fighter-bomber, and flew such types as the two seat Bf 110 as well as the Bf 109E.

Another veteran of the First World War was Oberst Werner Junck, and he was the commander of Jafü 3, giving him command of Stab, I. and II./ZG 2 as well as V.(Z)/LG 1. The Battle of Britain was the last aerial campaign where the German side was led by veterans of the First World War. For example, Kommodore of ZG 26, Oberst Joachim-Friedrich Huth served with Jasta 14 in 1917 and 1918, ZG 2 CO Obstlt. Friedrich Vollbracht scored two victories in Great War with Jasta 5 and two additional ones in spring 1940. This generation gradually left these positions as commanders of air assets, and by about the midway point of the battle with the RAF were replaced by younger and more aggressive flyers such as Oberst Ralph von Rettberg (ZG 2) or Oberst Johann Schalk (ZG 26).

The Luftwaffe conducted a 'contact phase' over The English Channel over the course of July 1940. Its purpose was to probe the tactics and capabilities of the enemy. At the same time, it was to reduce the assets of the RAF. The bulk of these operations were the responsibility of Jagdgeschwader 51, several other individual fighter groups (Jagdgruppen) and elements of the above mentioned Zerstörer units. These ac-



*Commander of II./ZG 76 Hauptmann Erich Groth (left) and Oberleutnant Hans-Joachim Jabs of 6./ZG 76 during Knight Cross awarding ceremony on October 1st, 1940 after scoring 12 and 19 victories respectively. Groth was killed in accident in 1941, but Jabs survived war. He became one of most successful night fighters and Kommodore of NJG 1. Photo: Narodowe Archywm Cyfrowe*

tions involved escorting bombers that were harassing shipping convoys, as well as fighter sweeps, which were conducted over the southeast of England. The main goal was to gain superiority over the English Channel, and the Germans also referred to this period of the war as 'Kanalkampf'.

The Channel was a significant psychological barrier to overcome for the German pilots, who were trained for years for combat over dry land. The awareness of the fuel gage, the compass and time were more relevant under the new conditions. Despite initial fears and trepidations, only a few pilots ended up in the drink due to the exhaustion of their fuel. The vast majority of pilots who had to ditch in the Channel had to do so for reasons of damage sustained in combat as opposed to having run out of gas. To this end, the Germans made efforts to ensure the best chances of survival for their airmen by providing rescue services. There was even a case of a German pilot being rescued by his colleagues from the mouth of the Thames!

The Germans did manage to gain air superiority over the Channel during 'Kanalkampf', but the RAF turned out to be a very capable opponent. John Vasco wrote in one of his books: 'In the early days of July, III./ZG 76 suffered losses on an escort mission for Stukas against shipping in the Channel. The 110 units also escorted He 111, Ju 88 & Do 17 units during the Battle. The majority of their missions were flying

as pure escort units more often than not. Flying at around 200mph or less, with the slow, lumbering, bombers, they were bounced often by RAF fighters flying considerably faster, up towards 300mph and above, they were often at a great disadvantage, hence the level of their losses.'

The RAF also experienced Bf 110 crews creating a defensive circle (Abwehrkreis), but this was not always an entirely defensive maneuver. Bf 110 airmen often used it to attract the attention of the enemy and allow their bomber colleagues to escape.

However, if a Bf 110 crew had the freedom to choose the tactical situation, the advantages of the Bf 110 could be used with great success against Spitfires and Hurricanes, such as concentrated firepower, long range, better initial acceleration in a dive, better rate of climb and a higher operational altitude.

Over the latter half of July and the first week of August, northwestern France saw a significant influx of fighter units. From the German point of view, the Battle of Britain began on August 8th, 1940, when the so-called 'Intensified Phase of the War Against England' (verschärferte Luftkrieg gegen England) began and lasted to the end of October of the same year.

These fifty days, however, did not involve a concentrated, day-to-day struggle. For example, there were twelve days of complete aerial inactivity brought on by lousy weather. German actions over eighteen days were considered light, with a total of under 200 sorties. In most cases the sorties were weather reconnaissance and intercepts of Allied aircraft over France and Belgium. Only on fifteen days, the number of combat sorties was so high, that there was a specific number of pilots that flew more than once.

After two days of widespread combat over England, the Germans began Operation 'Eagle Attack' (Unternehmen Adlerangriff) on August 13th, which was an intensive phase in the confrontation with the RAF, and raids on her infrastructure. This day had the codename 'Eagle Day' (Adlertag) and started a week of the battle. By August 18th, German



*Open cockpit of Bf 110 provided very little protection for the crew. During Battle of France and Battle of Britain the rear gunners were quite successful in defense against enemy fighters. Later in the war with heavier armament of Allied fighters the Bf 110 gunners had much smaller chance. Photo: Bundesarchiv via Wikimedia Commons*

fighter pilots (on Bf 109s and Bf 110s) claimed 386 kills for the loss of 61 downed or heavily damaged Bf 109s and 70 two-seat Bf 110s. Over that time of just short of a week, the Luftwaffe lost 93 twin-engined bombers and 42 Ju 87 Stuka dive-bombers. The Ju 87 was no longer utilized over England from that point on. However, it wasn't so much a result of the losses themselves, which were quickly made good, but rather for the type's range limitations. After August 15th, bombers of Luftflotte 3 and 5 were relieved of daylight bombing duties and began only nighttime operations.

A week after Adlertag, the Luftwaffe leadership decided that a change in the way fighter escorts were conducted was in order. They were required to stay as close as possible to those in their trust, which took away their main tactical advantage - freelance escort missions, spotting the enemy and attacking in time from a height advantage.

At the beginning of September the RAF began to concentrate solely on the bomber formations, and tried to ignore those formations that the radar stations identified as fighters. On September 5th the Luftwaffe decided to attach a Staffel to every Jagdgruppe, and task them with bombing missions. In this way, the Germans reduced their fighter capacity, fighters which might have played a pivotal role in the defeat of the RAF, which wasn't all that far off to begin with. Another, and more critical mistake, came on September 7th, when the Germans decided to switch their focus from the infrastructure of the RAF to London. This led to many civilian casualties, but the RAF was able to use this time to reorganize and replace losses. All came to a head on September 15th over eastern London, when a combination of bad weather and a well coordinated RAF intercept caused the Germans to suffer their greatest losses during the Battle of Britain - 36 bombers and 22 fighters were either shot down or heavily damaged.

The Luftwaffe changed tactics once again on September 20th. Its fighter-bombers conducted bombing raids from altitudes of several thousand meters. The effectiveness of these raids was very low, and involved instilling fear into the general population, but it did force the RAF to send out fighters against fighter formations of the Luftwaffe.

In the following weeks, the Luftwaffe shifted tactics in various ways, and achieved partial success in combat against RAF fighters and during attacks by twin-engined bombers. An attack against Supermarine in Woolston was able to temporarily halt production of the Spitfire. By mid-October, in any case, the Germans put off the invasion of England, dubbed Operation 'Sea Lion' (Unternehmen Seelöwe), indefinitely. The danger of an invasion on the remaining free part of Europe had been eliminated. In hindsight, using the Bf 109 and Bf 110 as a bomber can be viewed as a waste, which themselves were in need of an escort. These missions were called Jaboensätze, and in October, the Luftwaffe conducted some 2,633 of them, most focused on London. This involved around 660 tonnes of explosives. The same amount of destructive potential could be delivered three years later on Germany by around 240 Boeing B-17s in one raid.

The Bf 110 silhouette was so recognizable it did not require the use of yellow identification markings, as in case of Bf 109s during the first half of the Battle of Britain. However, one color marking was introduced on Bf 110s in early September. The well documented cases of yellow cowls and completely yellow rudders of Bf 109s were ordered on September 9th, 1940, to be used as identifying features for aircraft used as fighter-bombers, which evidently included their escorts.

A similar measure applied to Bf 110 units. For instance, ULTRA intercepted an order for I./ZG 2 dated September 9th, concerning the marking of aircraft assigned to fighter-bomber missions. It specified that the front part of the fuselage was to be painted white. The instructions stated further that it must be possible to paint these on the aircraft within a half hour.

It is interesting to note that the Germans issued orders on September 3rd, requiring identifying markings on French civil and courier aircraft. This also involved yellow wingtips, as well as yellow ends of the fuselage to the length of about 2m, and the rudder.

Between August 8th and October 31st, 1940, the Luftwaffe paid for the Battle of Britain with the loss of 221 Bf 110s, either destroyed outright or heavily damaged. Approximately four hundred of their airmen were either killed in action, captured or seriously injured. German airmen including Bf 110 and bomber crews claimed 2,169 victories. Luftwaffe leadership assumed that about one-third of these could have been claimed by more than one pilot, and this would not be too far off actual RAF losses. Even so, the Luftwaffe could not objectively gauge the overall situation of the enemy and were led to make bad decisions. The British, in this regard, were in a much more favorable position, and thanks to radar, were able to effectively and appropriately react to tactical situations as they developed. As such, ULTRA, who was able to uncover German messages by deciphering the Enigma codes, didn't play a pivotal role in the direction that the fighting took. The Germans sent out most orders and instructions via land based telecommunication channels. ULTRA was able to uncover the preparations for 'Adlertag' but was not able to provide its meaning or timing.

The greatest losses suffered in one day by the Zerstörergruppen was August 15th. Bf 110 units lost 26 aircraft and an additional four were

**Bf 110D „M8+FH“ of I./ZG 76 with additional fuel tank under fuselage called „Dackelbauch“ (dachshund's belly). This unit was based in Stavanger, Norway and on August 15th, 1940 provided escort for Luftflotte 5 bombers based in Scandinavia. In combat against RAF the unit lost seven crews including commander and his Adjutant. Photo: SDASM**



**Bf 110 of III./ZG 26 is refuelled at Barley-Arques airfield in Autumn 1940. The emblem of ladybird was used by whole III. Gruppe. From October new commander of the unit was Major Karl Kaschka (1904 - 1941), a pre-war officer of Austrian Air Force. Photo: Bundesarchiv via Wikimedia Commons**

damaged. There are 31 kills credited to Bf 110 crews documented in German archives for this day, but the total number of confirmed victories was probably around 45. The highest number of victories achieved by Bf 110 crews in one day was probably scored on August 18th. The number of their victories was likely around fifty from a total 127 scored on that day by the Luftwaffe.

The most successful Bf 110 pilots between August 8th and October 31st were two pilots of 6./ZG 76 and future Knight Cross holders - Oblt. Hans-Joachim Jabs with 12 kills (total of 19 during 1940) and Oblt. Wilhelm Herget with nine victories. The unsung heroes of Bf 110 missions were the rear gunners. A good example is 'Bordfunker' for Oblt. Jabs. His name was Erich Weissflog and he scored 3 kills during 1940 and later stayed with Jabs as his night fighter crew. He was decorated with the Knight's Cross as well.

There were at least 22 Bf 110 pilots who became aces during Battle of Britain, but the actual number could be closer to thirty or forty. Among the known aces were at least four Austrians - Johann Schalk, Alfred Wehmeyer, Theodor Rossiwal (all from ZG 26) and Hartmann Grasser (ZG 2).

How successful was the Bf 110 in the role of fighter in the Battle of Britain? There are well documented victories and losses of Spitfire, Hurricane and Bf 109 units, giving their kill/loss ratios as 1.7, 1.2 and 1.5 respectively. The Bf 110 units are a bit enigmatic due to missing detailed records about their victories. Only 216 aerial victories are documented in detail between August 8th and October 31st, 1940. However this figure is based on records of only three Zerstörergruppen, while details of four others are completely missing!

However, from the data of the higher Luftwaffe command, it is known that during the above mentioned period, Bf 110 and bomber crews claimed almost 600 victories. If we accept the estimate that 75% of this figure was achieved by Bf 110 airmen, then we get an unexpected champion of the Battle of Britain. The kill/loss ratio for the Bf 110 would be 2.0!

Regardless of all individual and unit victories, the Luftwaffe gave up on the effort to achieve air superiority over England. The RAF won the Battle of Britain. The Luftwaffe suffered its first defeat and lost hundreds of highly experienced airmen. It was the first out of many defeats awaiting it in the coming five years and the RAF played a key role in them. The Bf 110 was withdrawn from most daytime operations over Western Europe and found a new role as a night fighter, but often, it fulfilled successfully the role of fighter bomber and long range fighter in the Mediterranean and on the Eastern Front.





Carefully read instruction sheet before assembling. When you use glue or paint, do not use near open flame and use in well ventilated room. Keep out of reach of small children. Children must not be allowed to suck any part, or pull vinyl bag over the head.



Před započatím stavby si pečlivě prostudujte stavební návod. Při používání barev a lepidel pracujte v dobře větrané místnosti. Lepidla ani barvy nepoužívejte v blízkosti otevřeného ohně. Model není určen malým dětem, mohlo by dojít k požití drobných dílů.

## INSTRUCTION SIGNS

## INSTR. SYMBOLS

## INSTRUKTION SINNBILDEN

## SYMBOLES

## 記号の説明

OPTIONAL  
VOLBABEND  
OHNOUTSAND  
BROUSITOPEN HOLE  
VYVRTAT OTVORSYMETRICAL ASSEMBLY  
SYMETRICKÁ MONTÁŽREMOVE  
ODŘÍZNOUTREVERSE SIDE  
OTOČITAPPLY EDUARD MASK  
AND PAINT  
POUŽIT EDUARD MASK  
NABARVIT

## PARTS



## DÍLY



## TEILE



## PIÈCES



## 部品

## PLASTIC PARTS

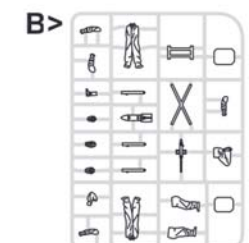
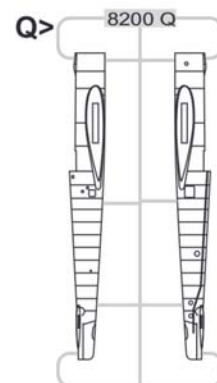
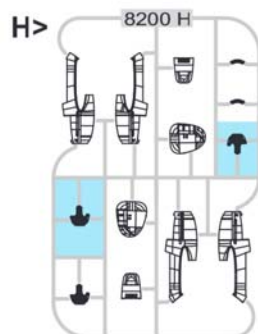
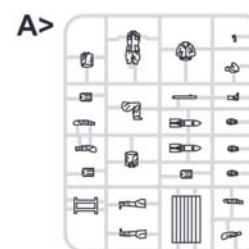
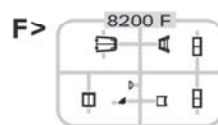
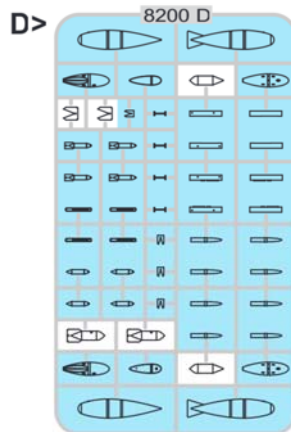
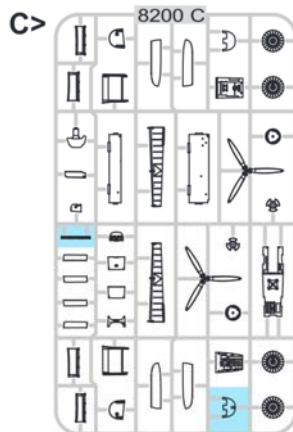
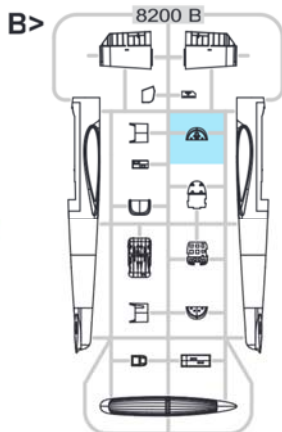
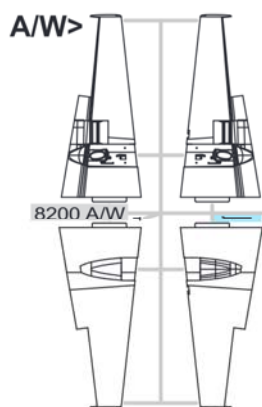
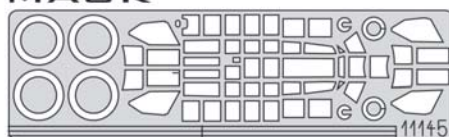
eduard  
MASK

## PE - PHOTO ETCHED DETAIL PARTS

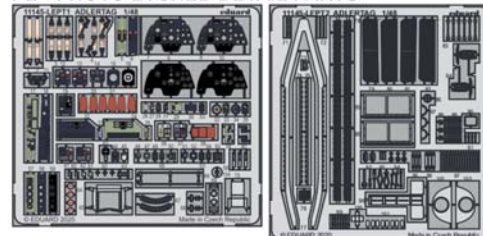

## RP - RESIN PARTS



-Parts not for use. -Teile werden nicht verwendet. -Pièces à ne pas utiliser. -Tyto díly nepoužívejte při stavbě. - 使用しない部品

## COLOURS



## BARVY



## FARBEN



## PEINTURE



## 色

GSI Creos (GUNZE)		MISSION MODELS	
AQUEOUS	Mr.COLOR	PAINTS	
H5	C5	MMP-048	BLUE
H7	C7	MMP-002	BROWN
H11	C62	MMP-001	FLAT WHITE
H12	C33	MMP-047	FLAT BLACK
H37	C43		WOOD BROWN
H47	C41	MMP-012	RED BROWN
H64	C17	MMP-087	RLM71 DARK GREEN
H65	C18	MMP-088	RLM70 BLACK GREEN
H67	C115	MMP-057	RLM65 LIGHT BLUE
H70	C60	MMP-056	RLM02 GRAY
H77	C137	MMP-040	TIRE BLACK

GSI Creos (GUNZE)		MISSION MODELS	
AQUEOUS	Mr.COLOR	PAINTS	
H80	C54		KHAKI GREEN
H85	C45		SAIL COLOR
H43	C13	MMP-090	RLM04 YELLOW
H44	C14		RLM23 RED
H46	C16	MMP-089	RLM66 BLACK GRAY
Mr.METAL COLOR		METALLICS	
MC23		MMM-006	STAINLESS
MC24		MMM-001	DARK IRON
MC29		MMM-009	BRASS
Mr.COLOR SUPER METALLIC		METALLICS	
SM20		MMC-001	SUPER FINE SILVER

**MARKING ONLY**

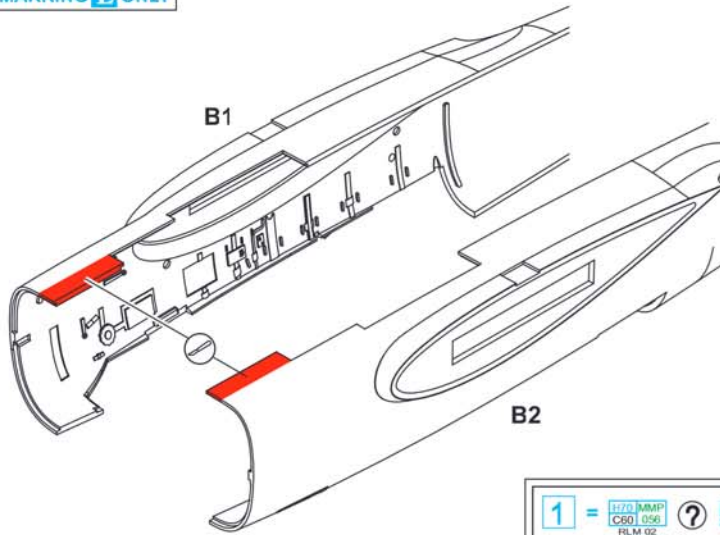

**A** 3 pcs.



**B** 3 pcs.

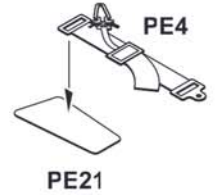

**1** = **112 MMP C60 056** RLM 02 GRAY    **?** **112 MMP C118 099** RLM 66 BLACK GRAY

**Bf 110C** – cockpit color on early machines was RLM 02, on late machines RLM 66. But there are exceptions. It depends on the manufacturers too. Instrument panels were in RLM 66 always.  
**Bf 110D** – cockpit color and instrument panel in RLM 66.

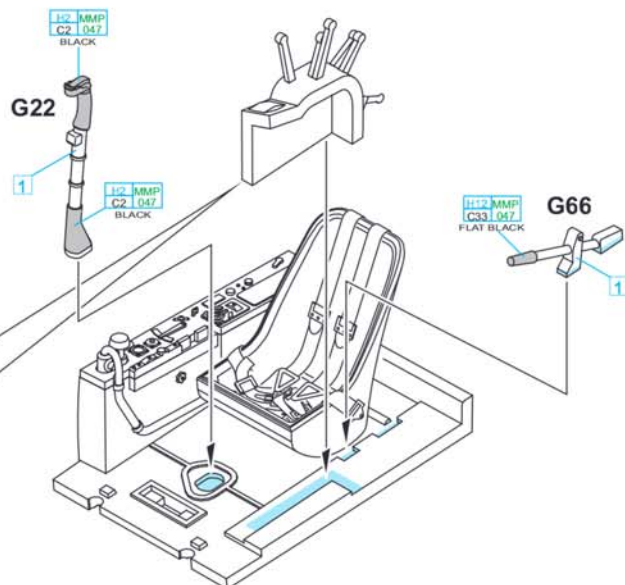
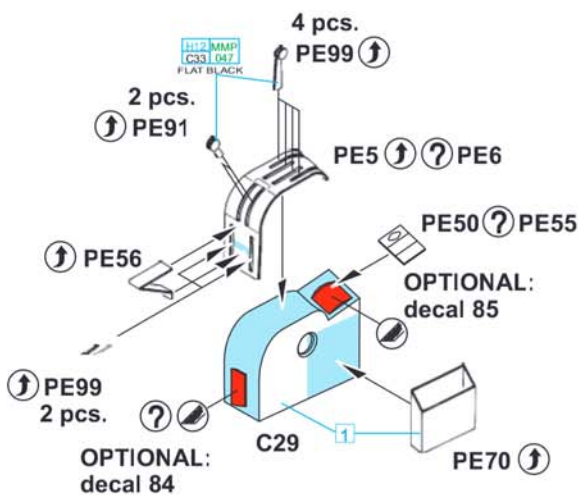
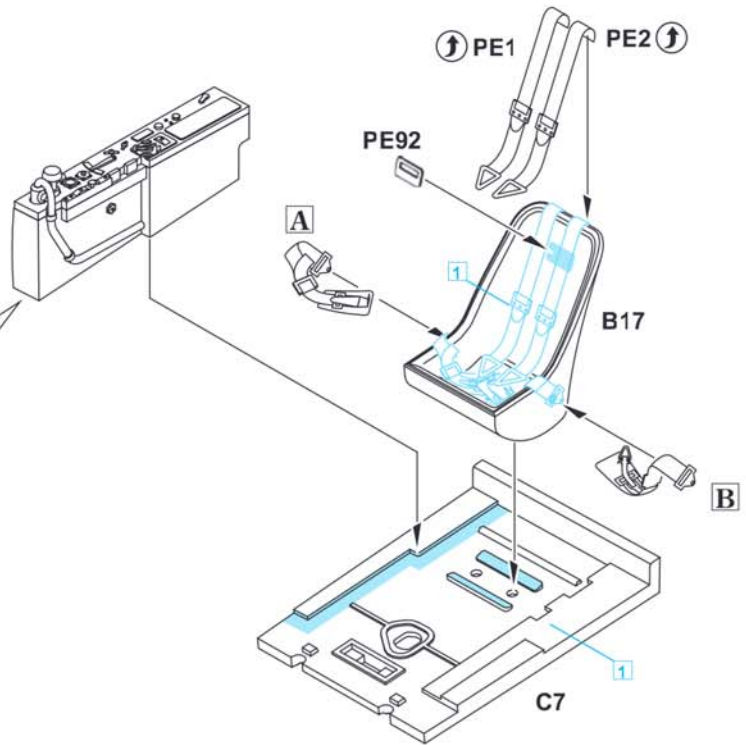
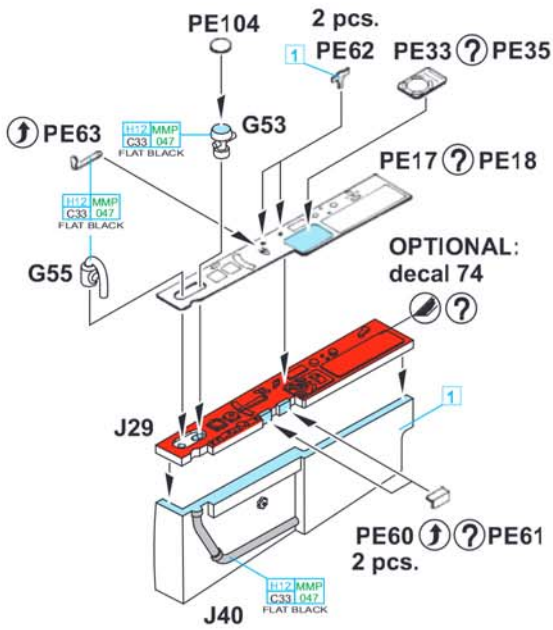

2 pcs.

PE84

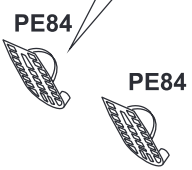

?

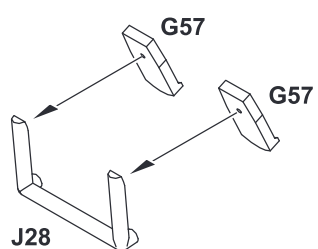

?

PE7, PE9 ? decal 104 - MARKINGS A; B; E; H; I; L  
PE8, PE10 ? decal 75 - MARKINGS C; D; F; G; J; K

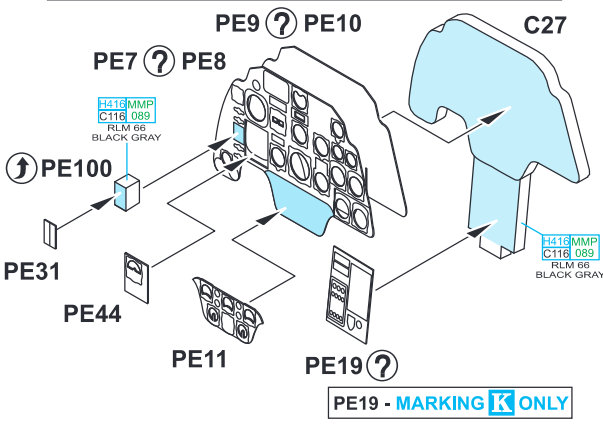

PE19 - MARKING K ONLY

?

H13

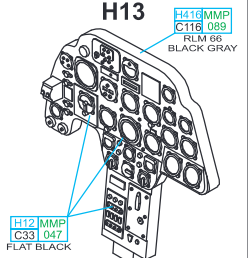

C27 ? H13



OPTIONAL:  
decals 75 ? 76 ? 104  
decals 76 - MARKING K ONLY

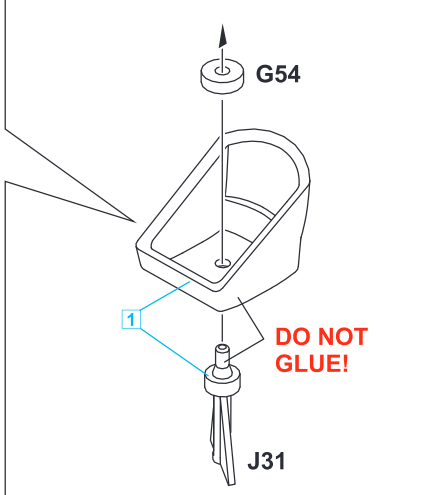
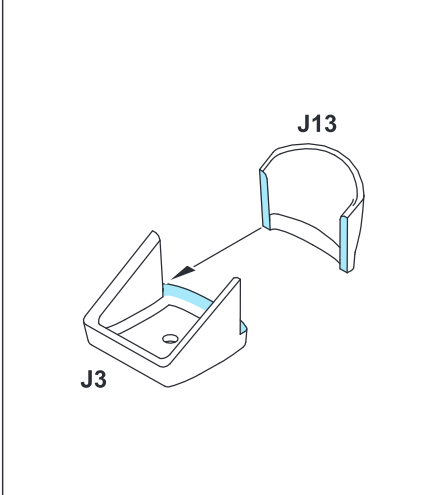

DO NOT GLUE!

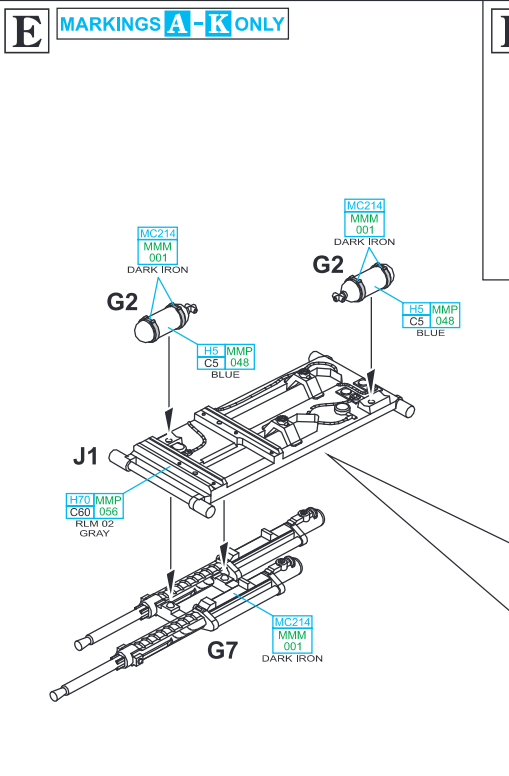
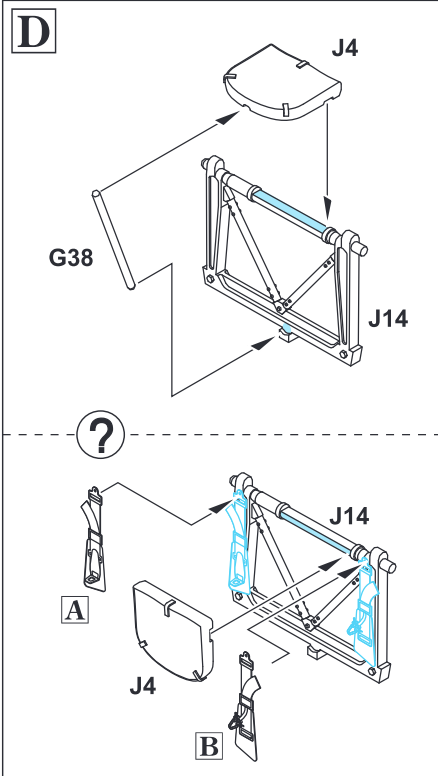
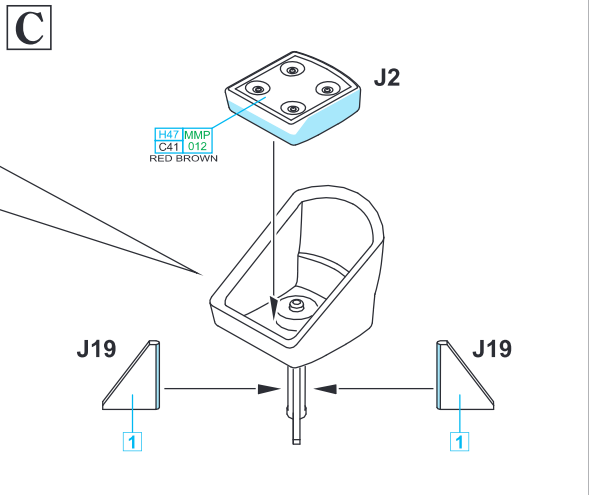

MARKINGS A-K ONLY

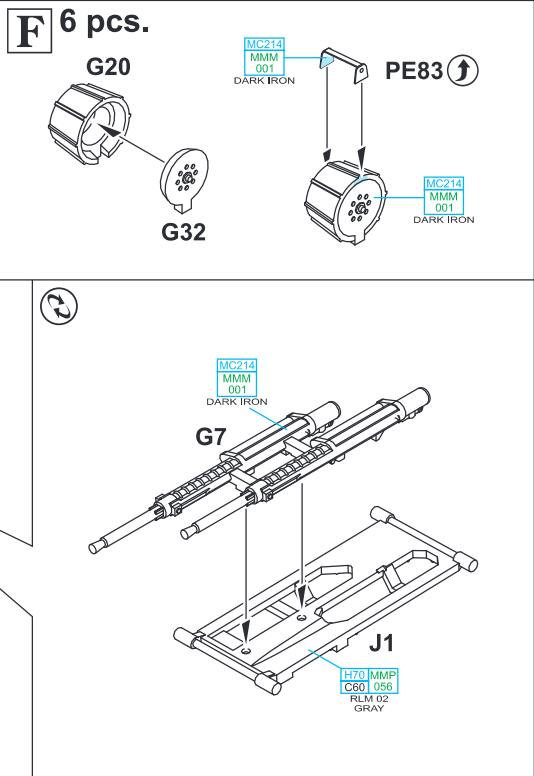

6 pcs.

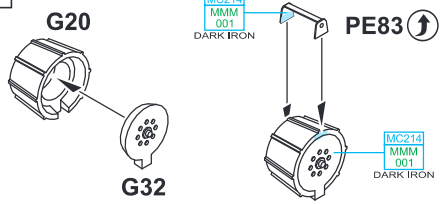

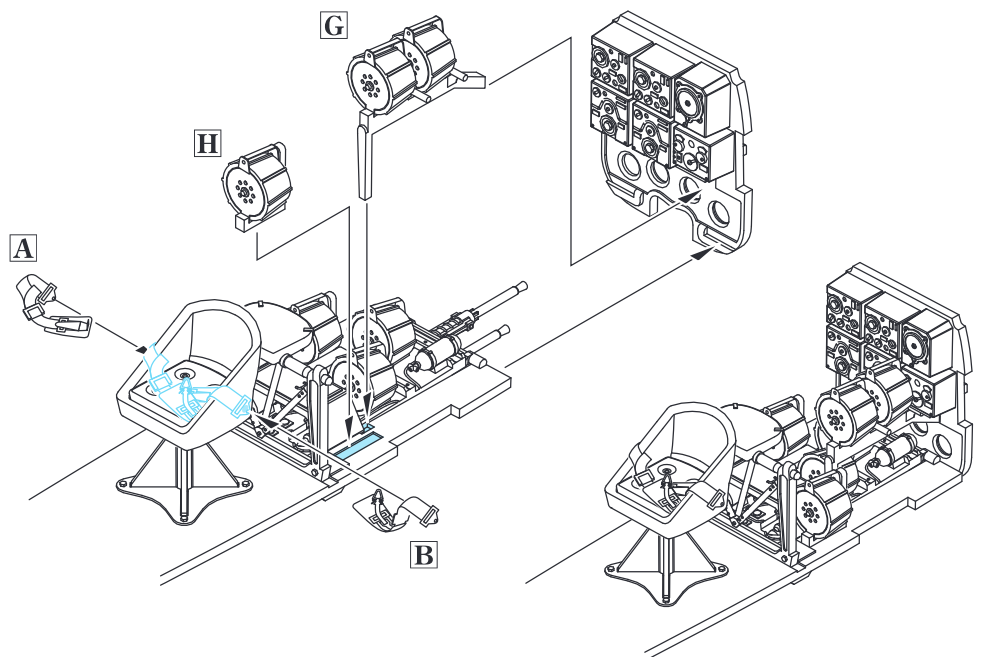
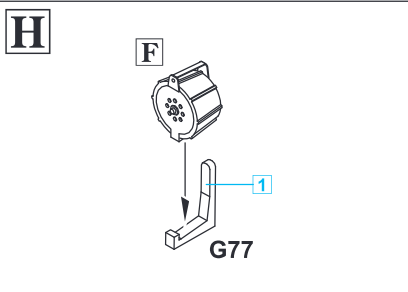
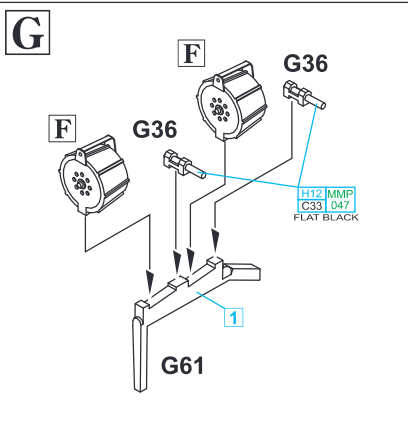
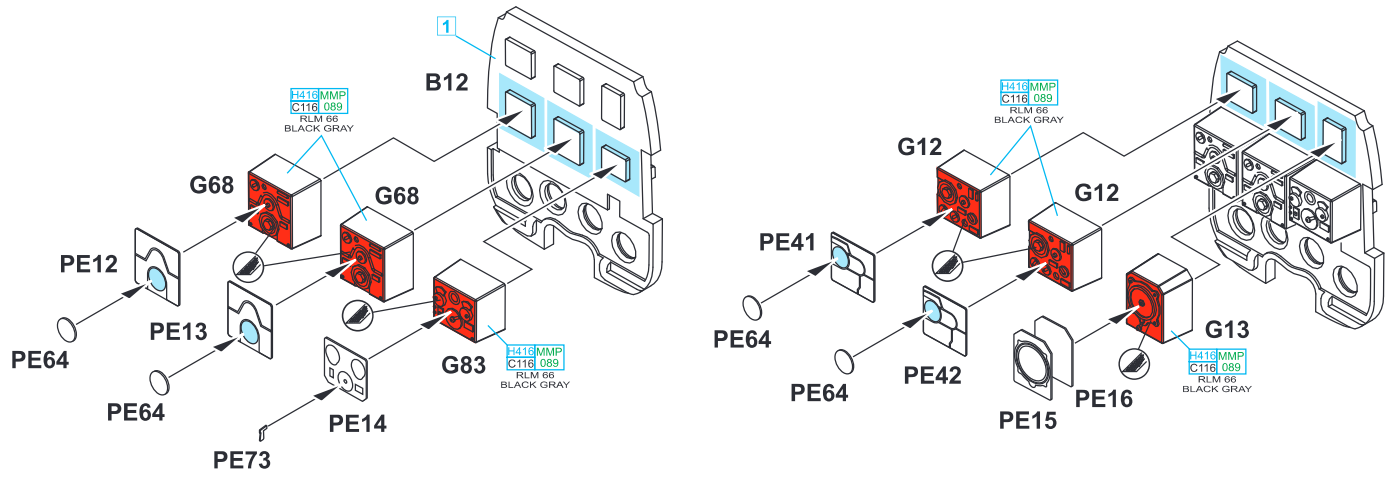
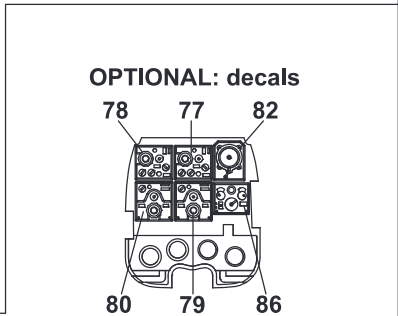
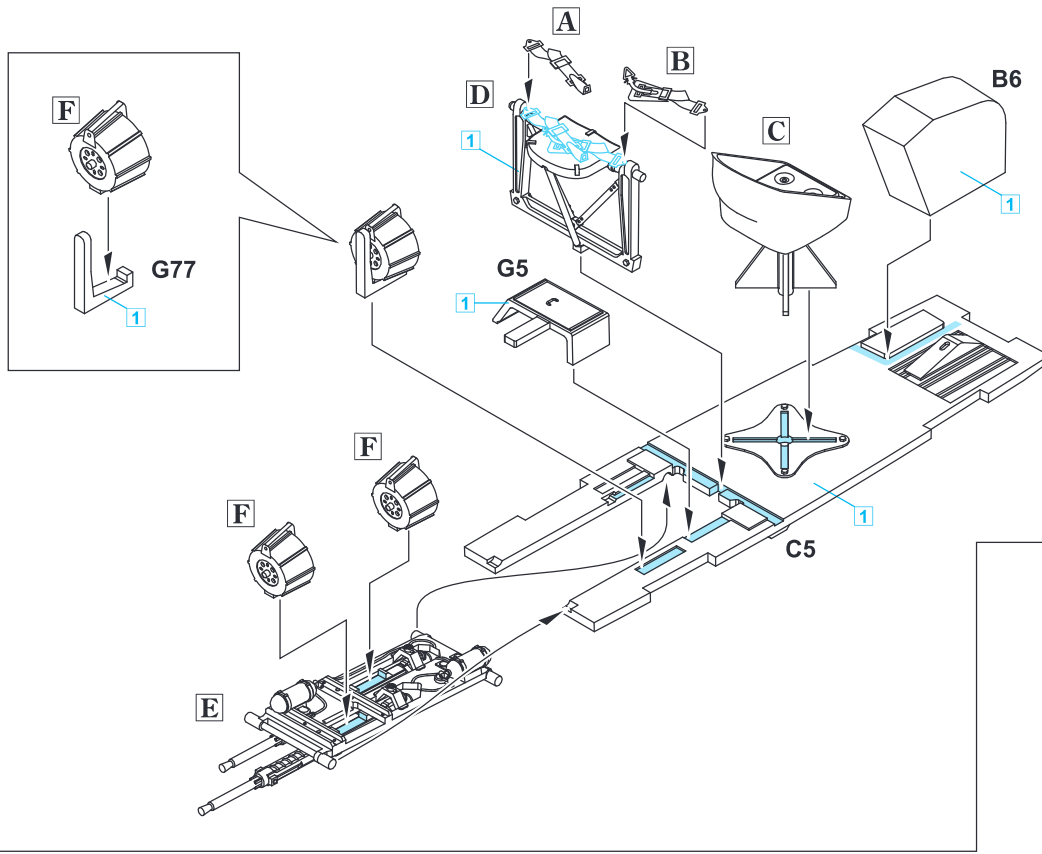

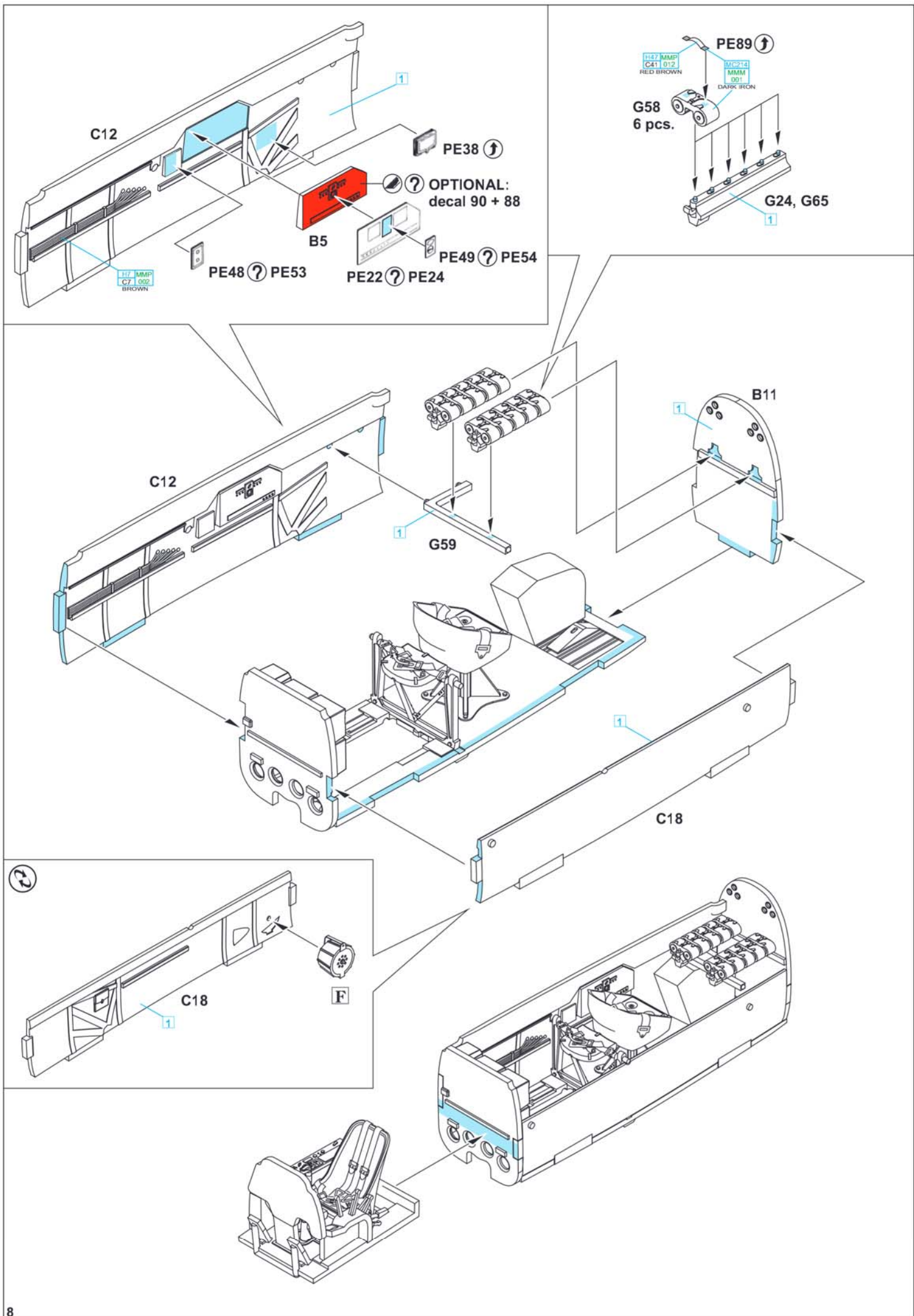

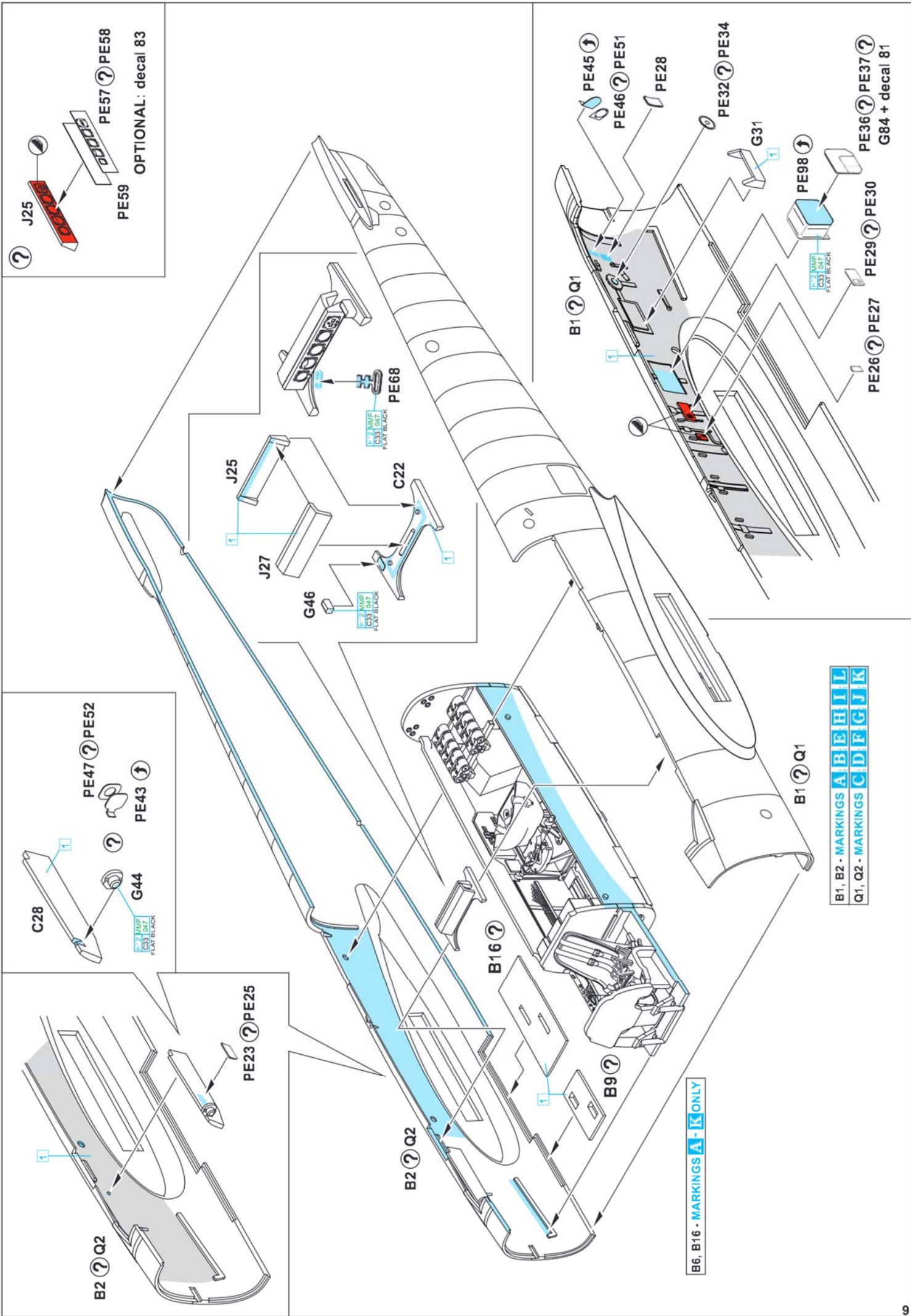



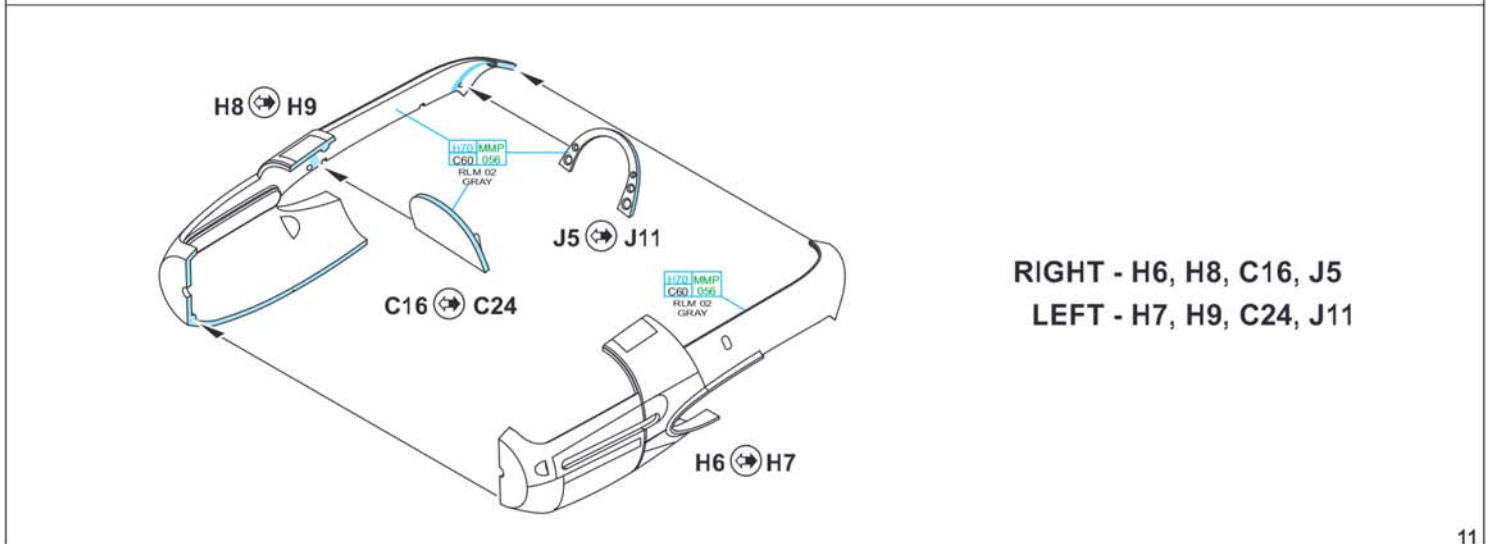
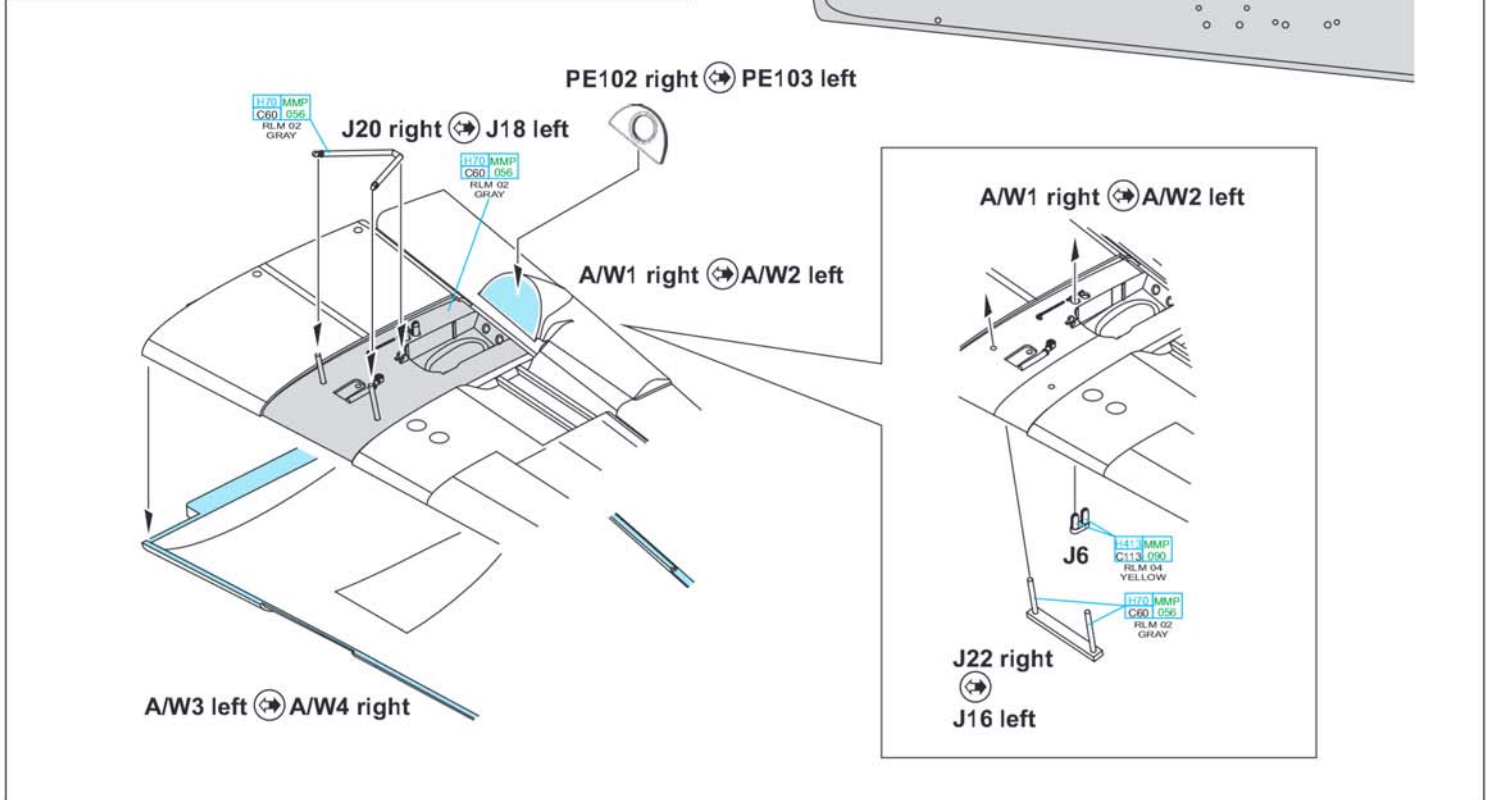
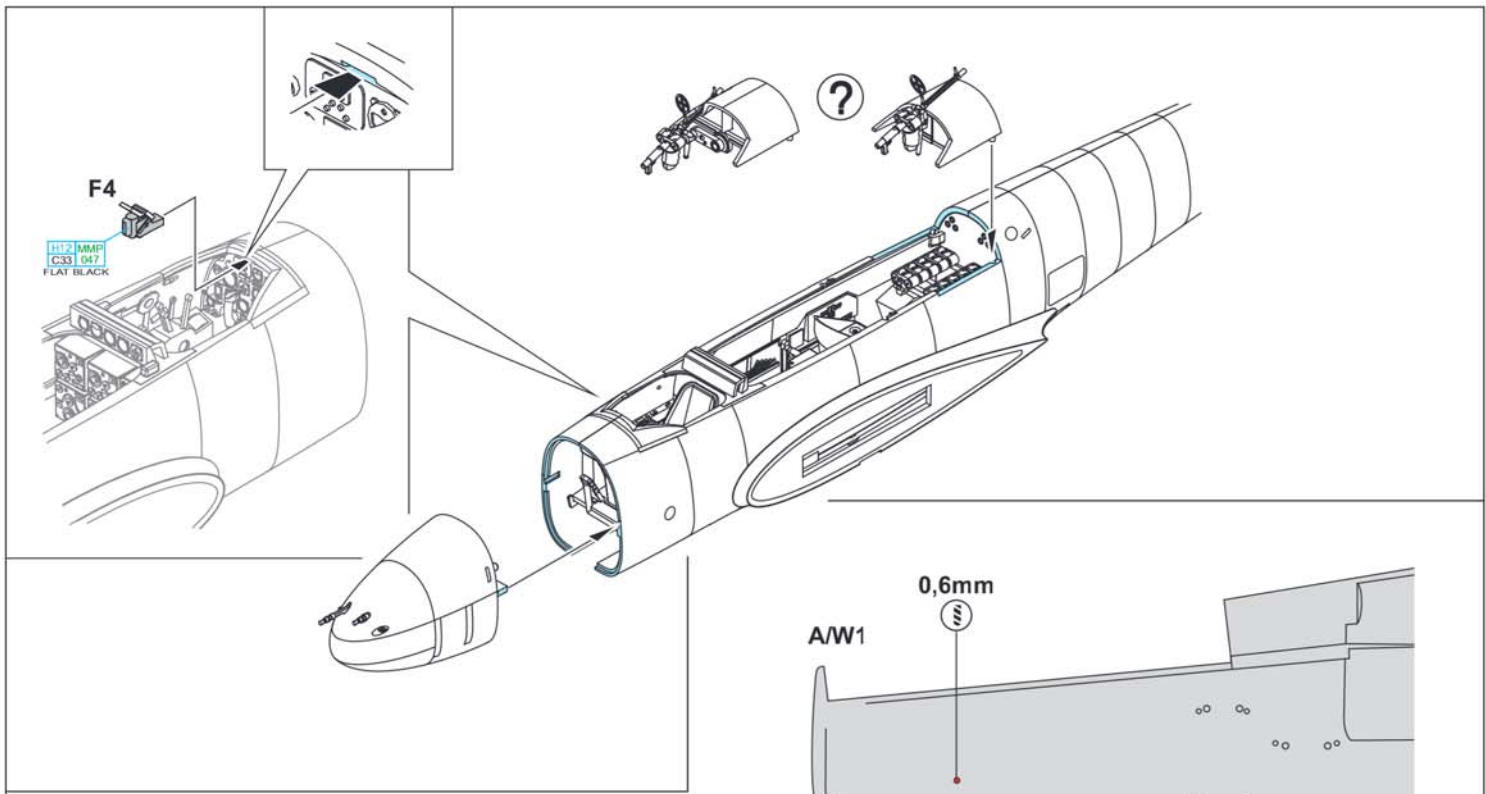

H2 right ↔ H1 left



H4 right ↔ H11 left

H2 right ↔ H1 left

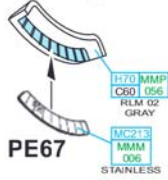

H4 right ↔ H11 left

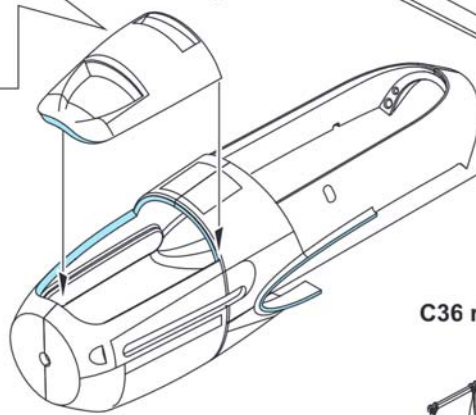

C36 right ↔ C25 left

C35 right ↔ C26 left

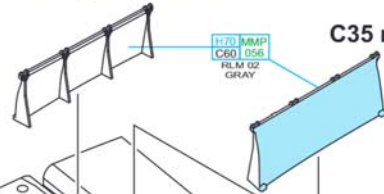

**GLUE THE WHEEL WELL SIDES STRICTLY AFTER THE ENGINE NACELLES ARE GLUED ONTO THE WING!**

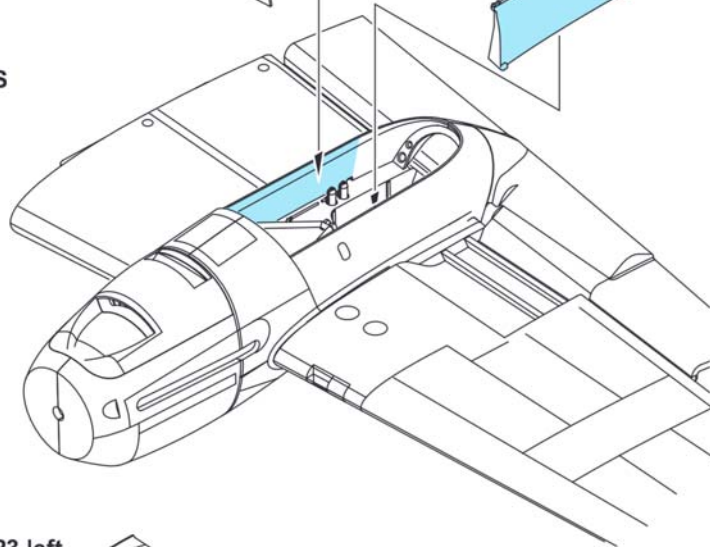

C17 right ↔ C23 left

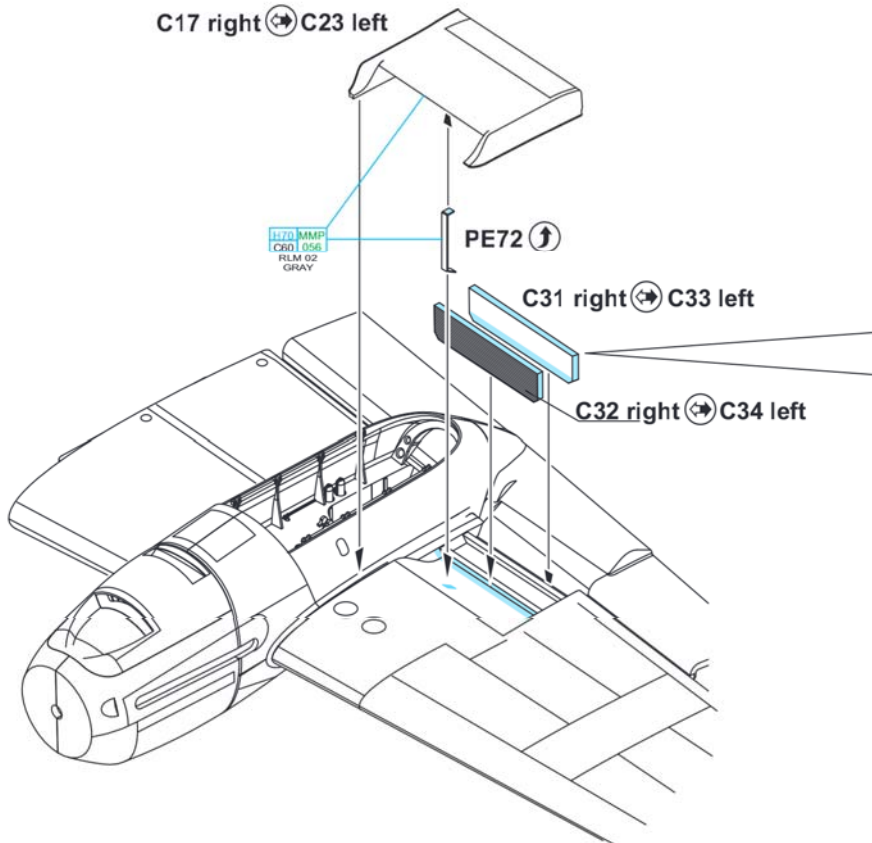

PE79 right ↔ PE81 left

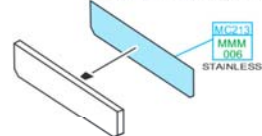

C31 right ↔ C33 left

C32 right ↔ C34 left

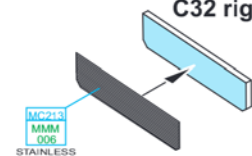

PE80 right ↔ PE82 left

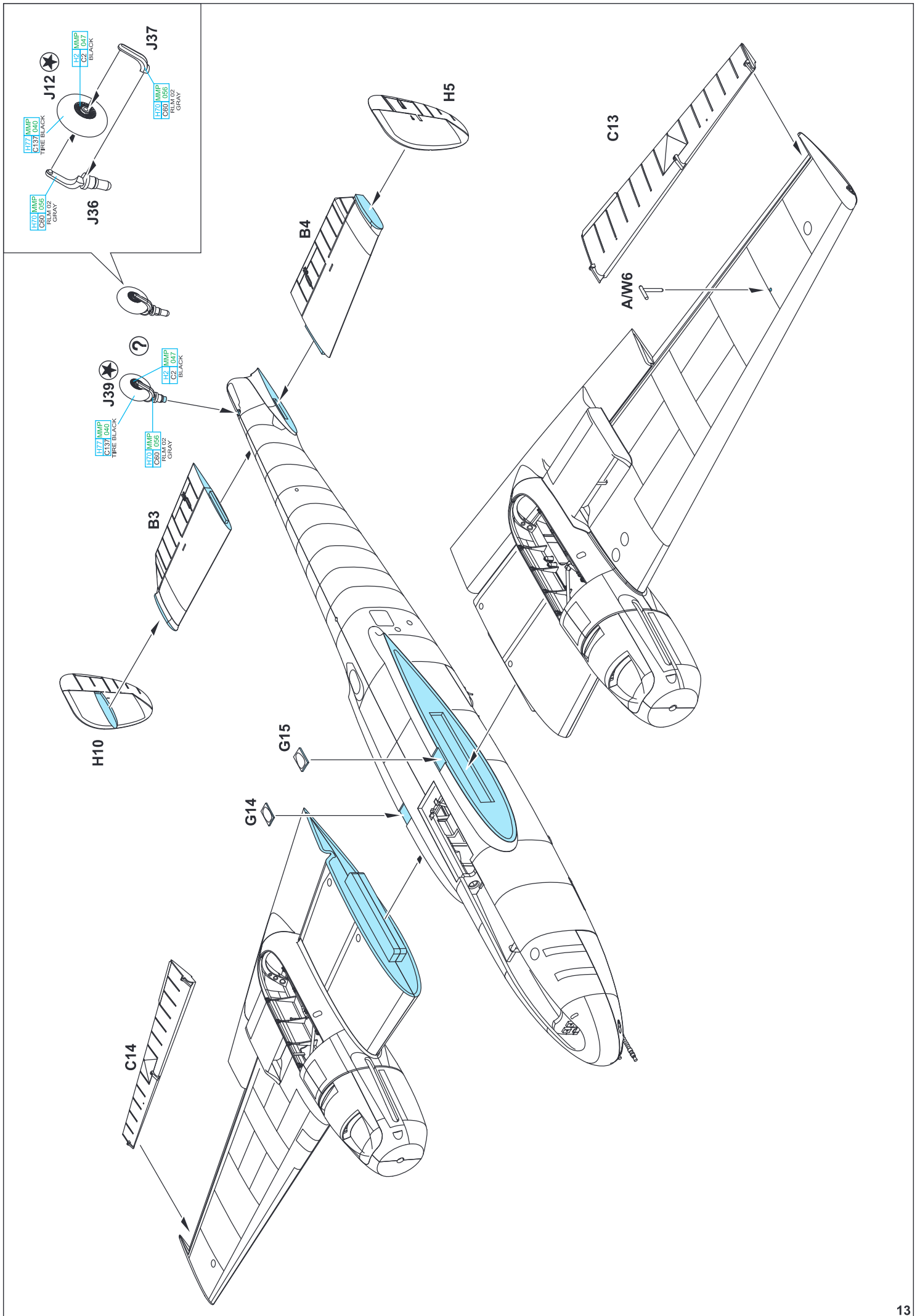

2 pcs.

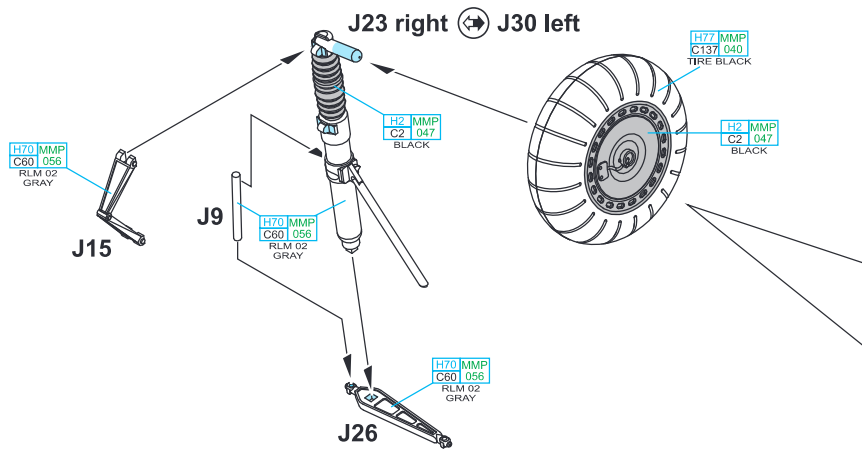

2 pcs.

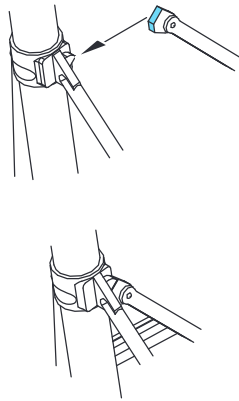
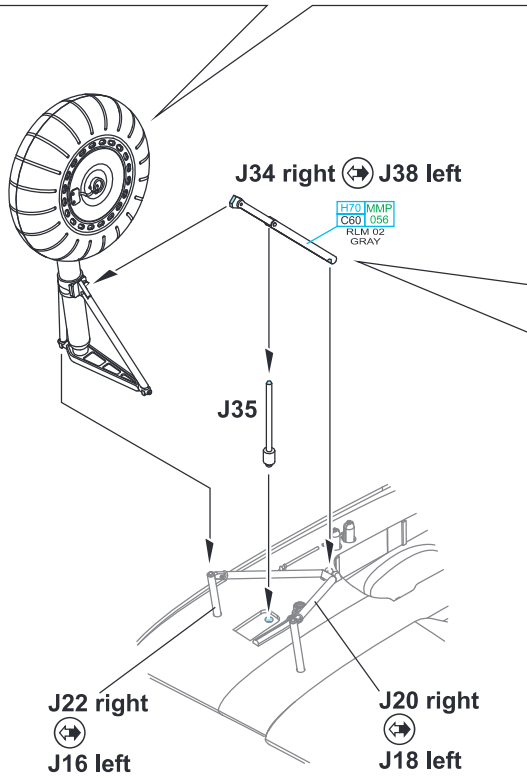
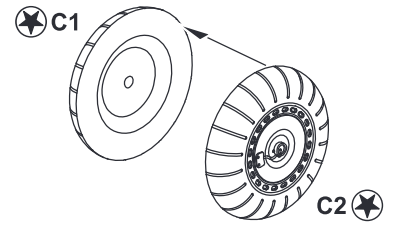

CORRECT POSITION OF WHEELS

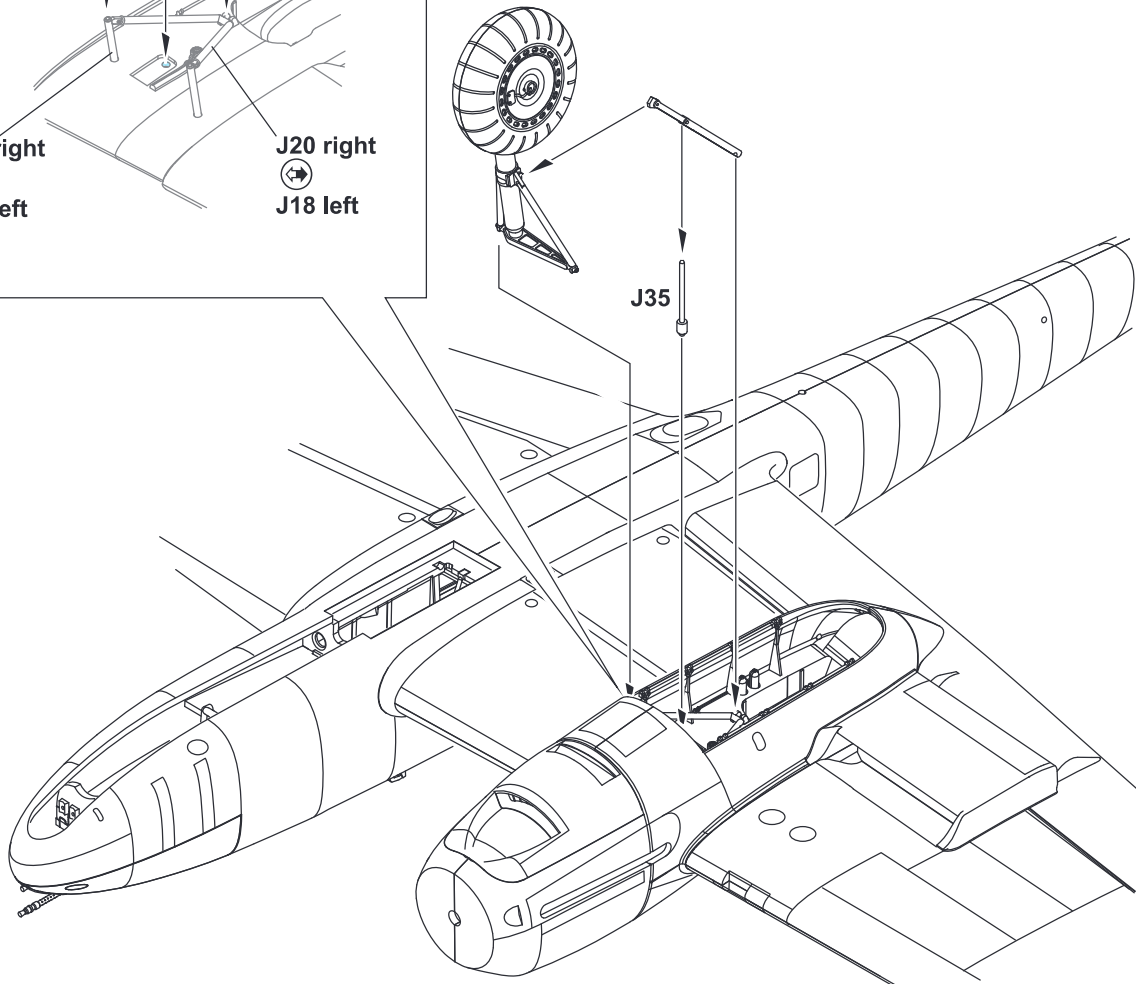

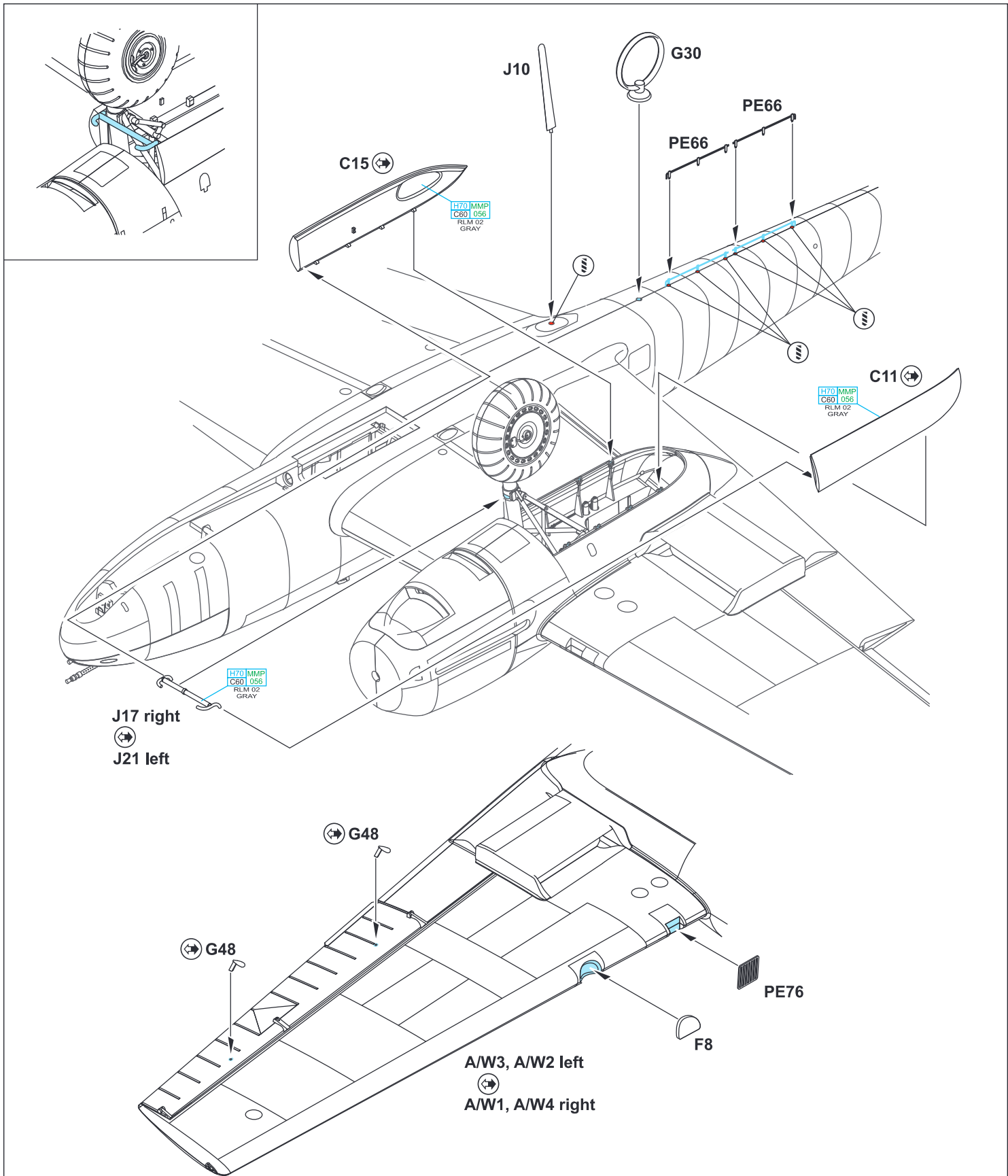

WE RECOMMEND TO GLUE J24/J32 EXHAUST BASES TO ENGINE NACELLES FIRST, NEXT GLUE THE EXHAUST PIPES TO THE BASES.

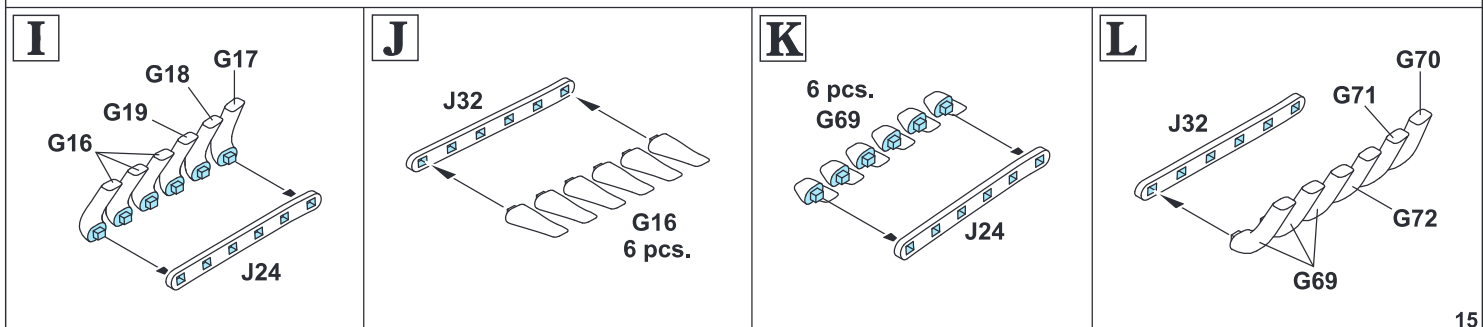

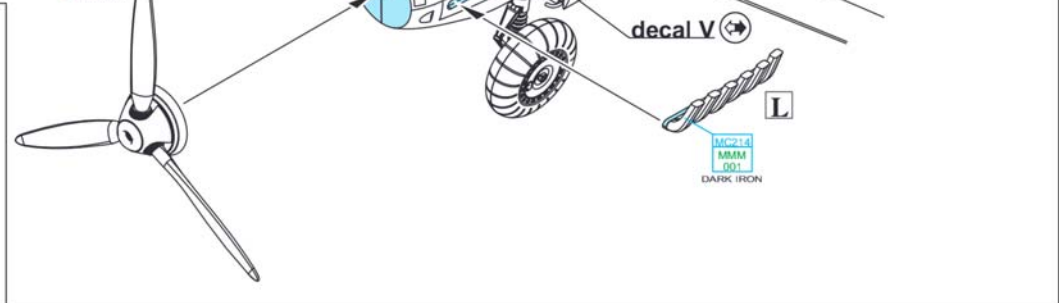
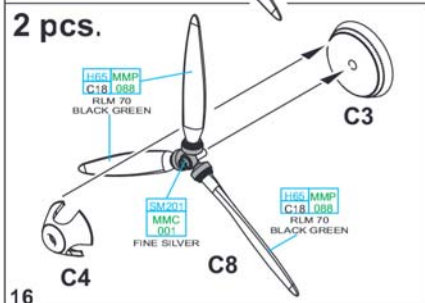
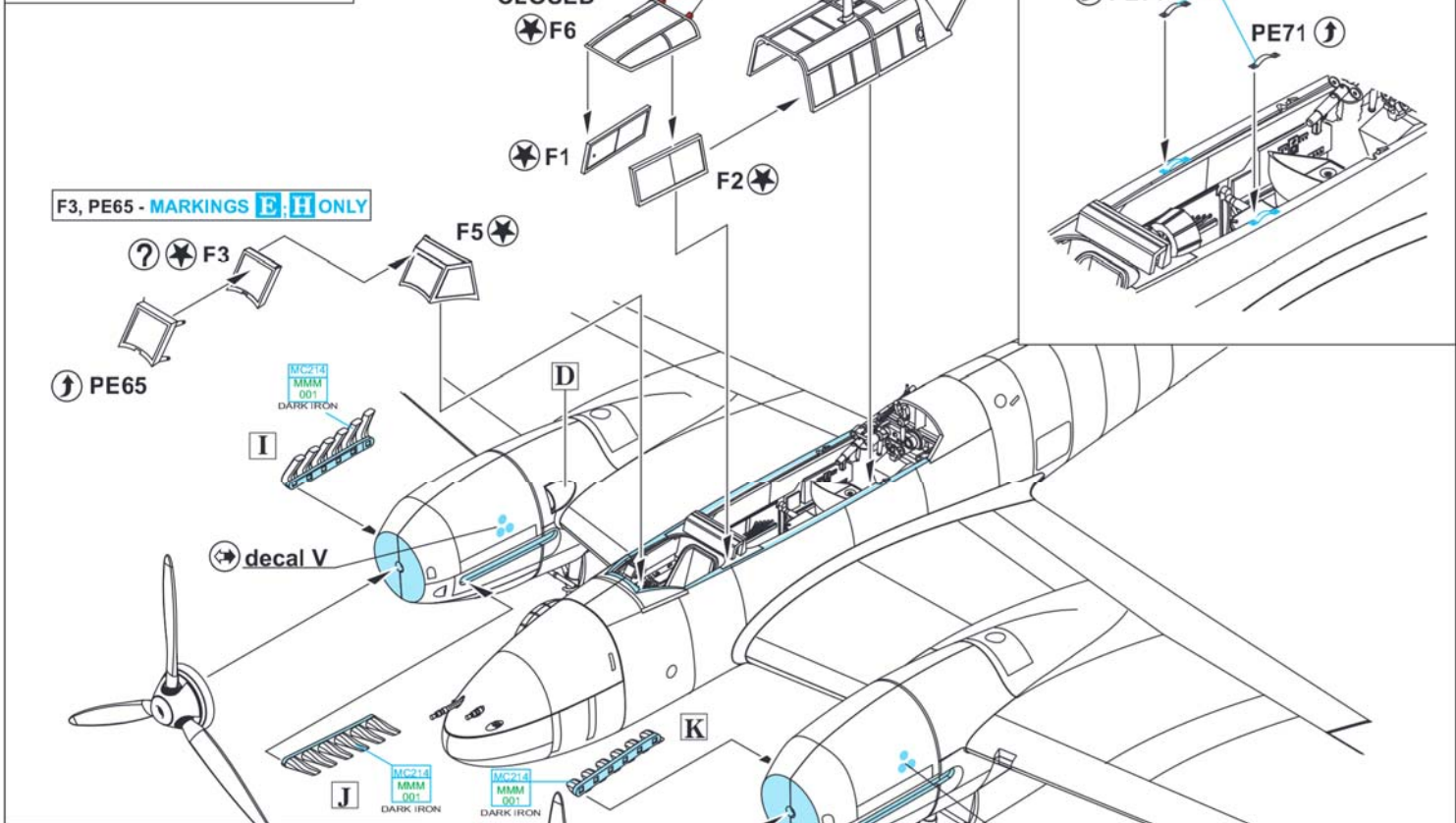
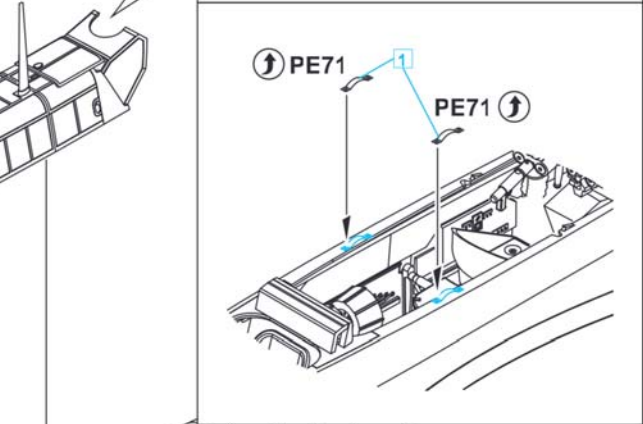
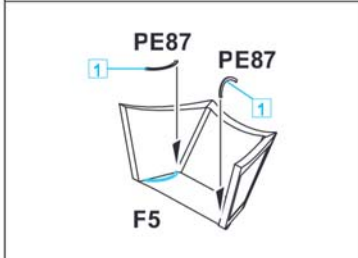
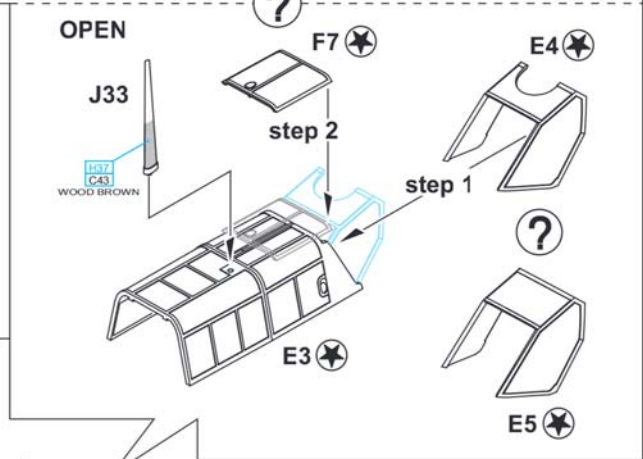
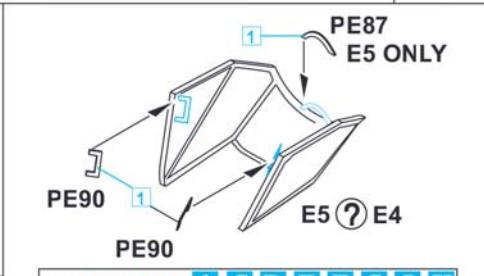
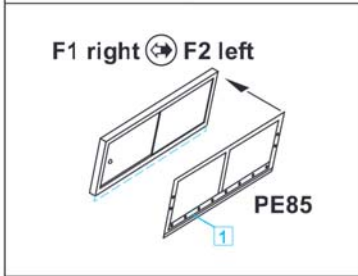
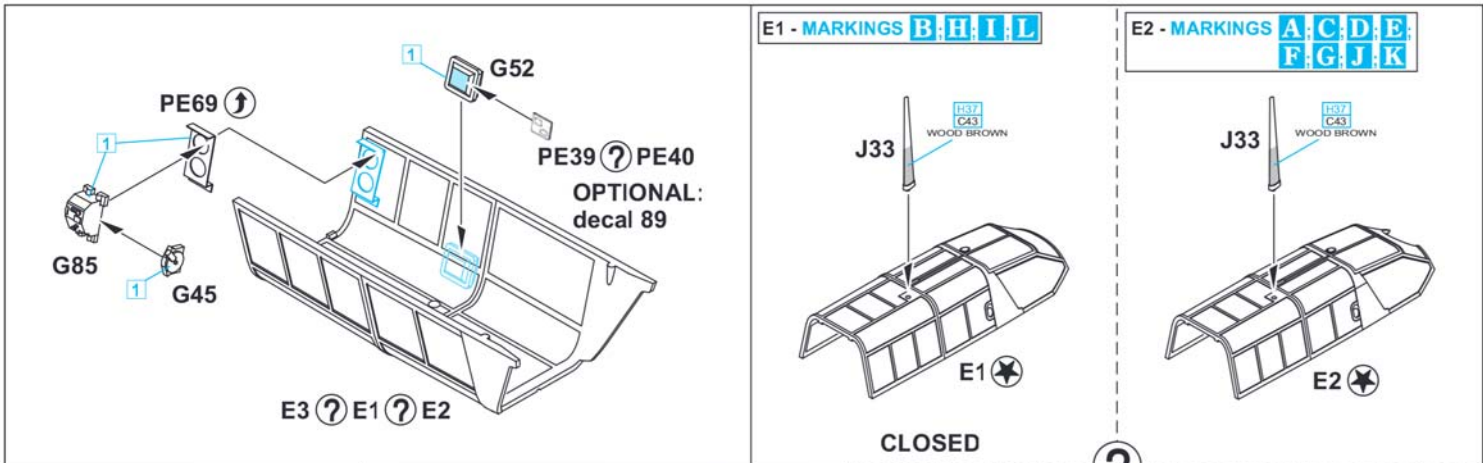

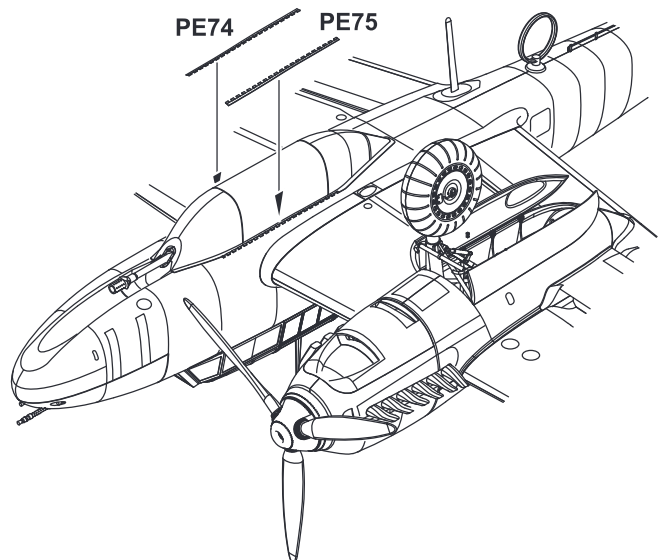
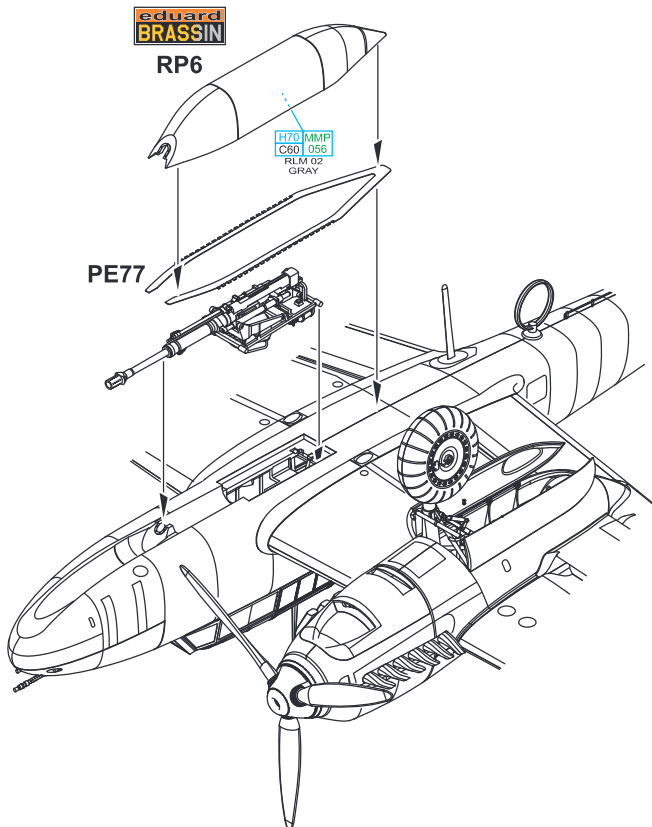
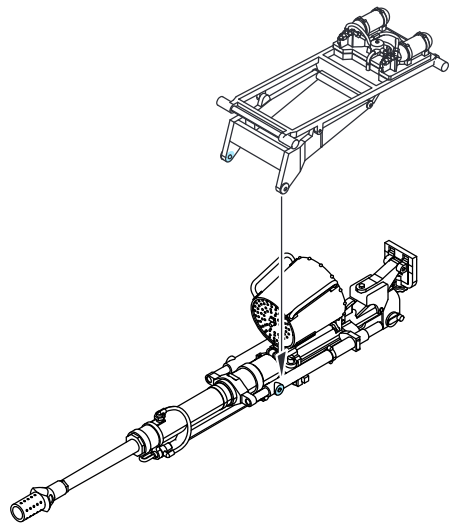
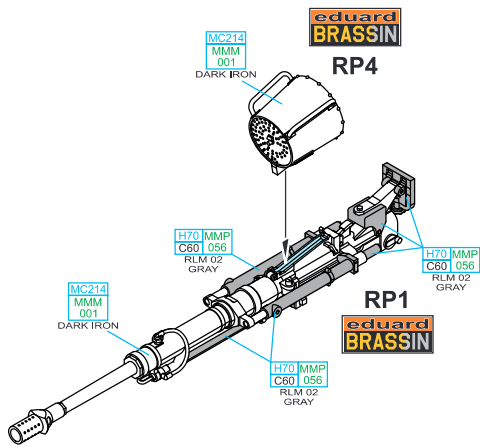
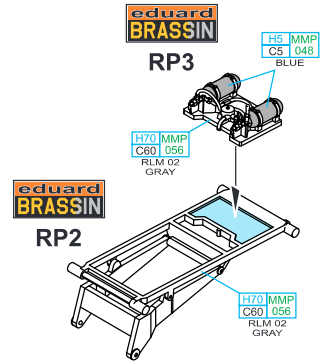
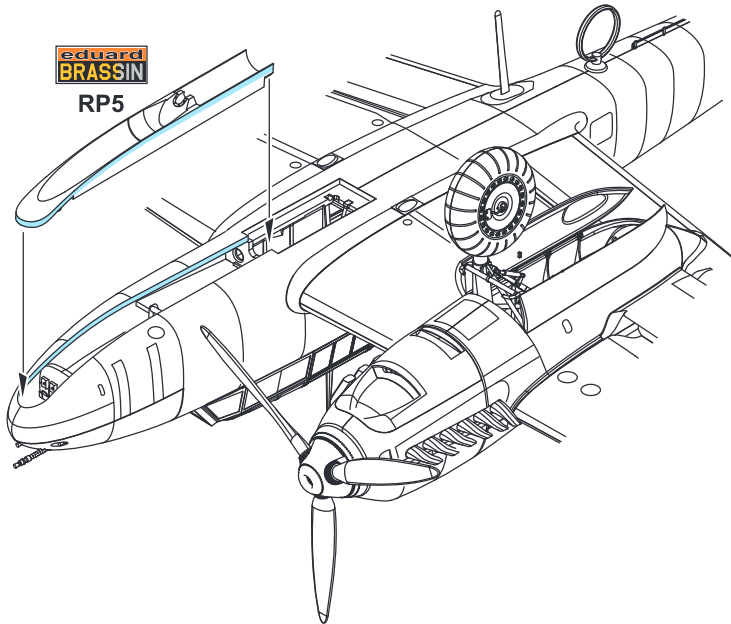

MARKING D ONLY

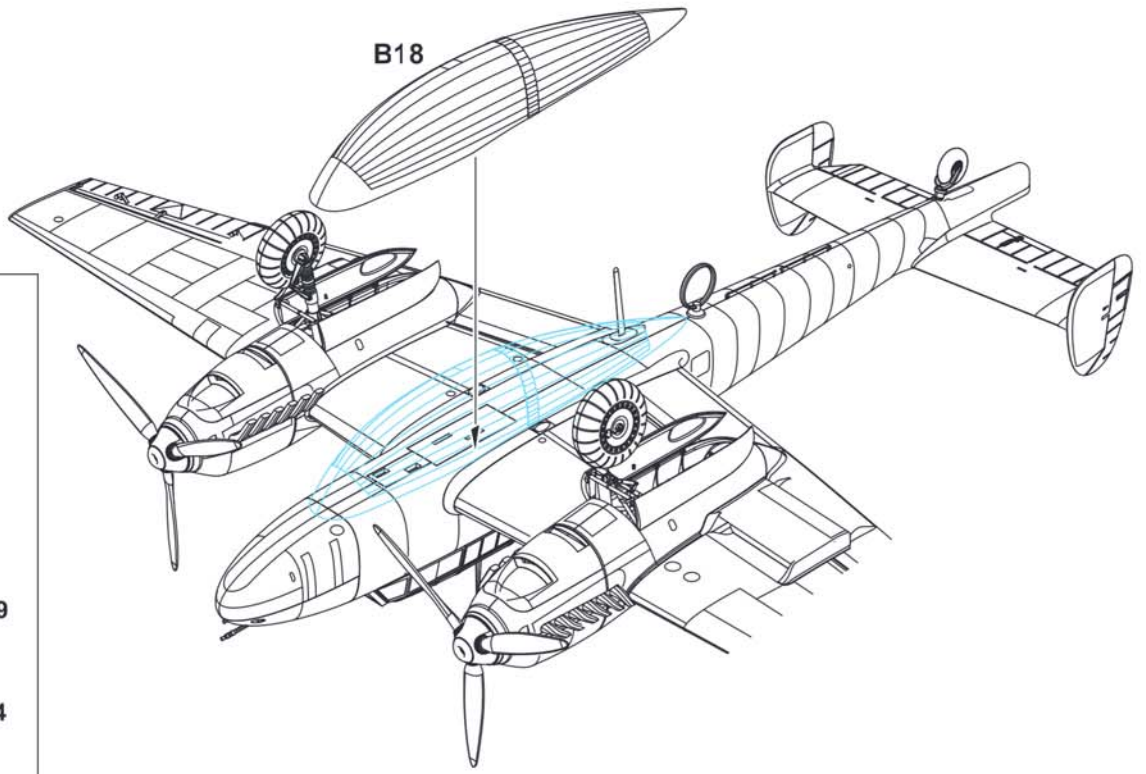

2 pcs.

D6

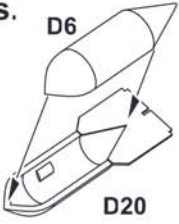

D20

D19

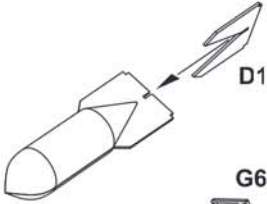

G64

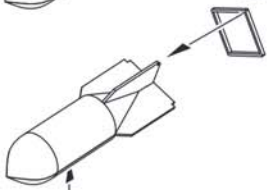

G42

MARKING K ONLY

C54  
KHAKI GREEN

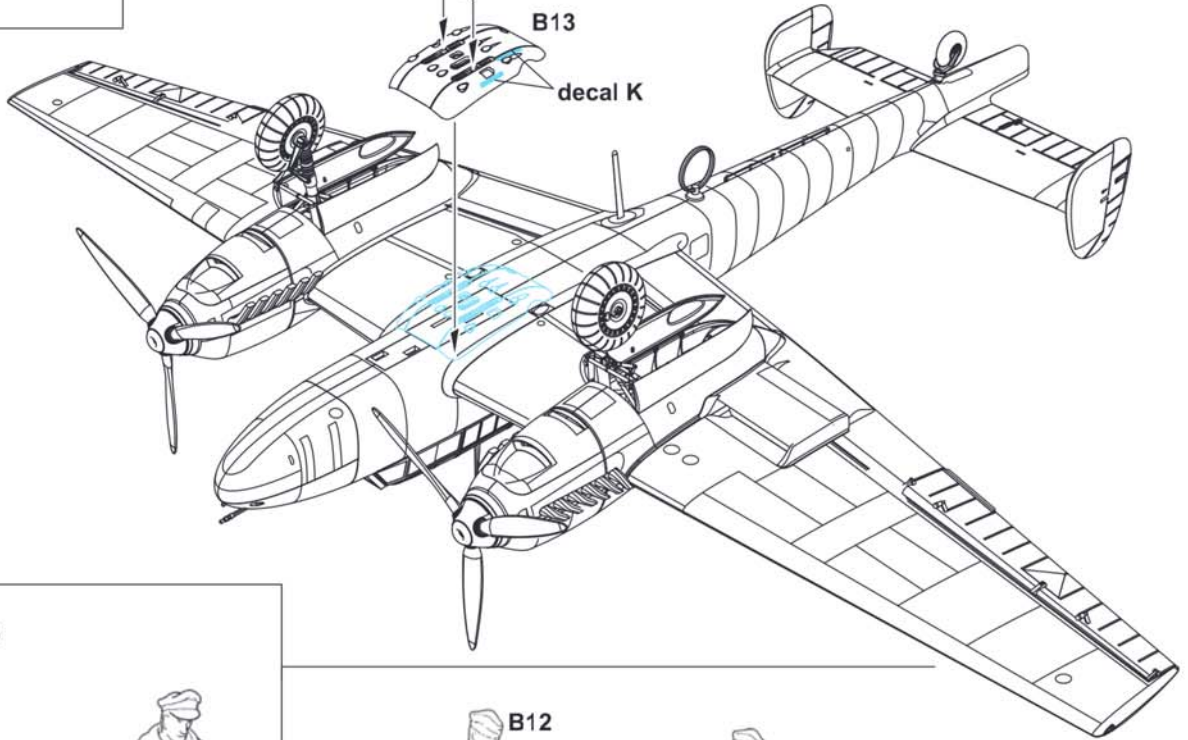

B13

decal K

B13



A3

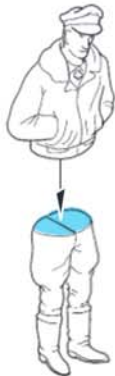

A21

A20

B12

A24

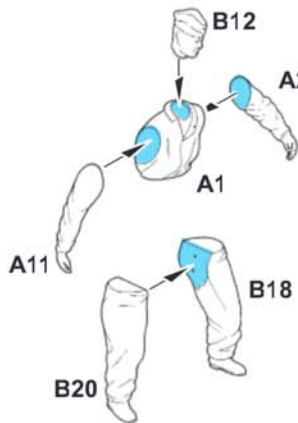

A1

B18

B20

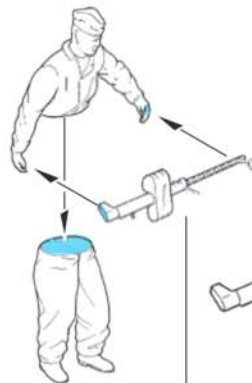

MC214  
MMM  
001  
DARK IRON

PE94

PE93  
MMM  
001  
DARK IRON

PE95

MC214  
MMM  
C41 B12  
RED BROWN

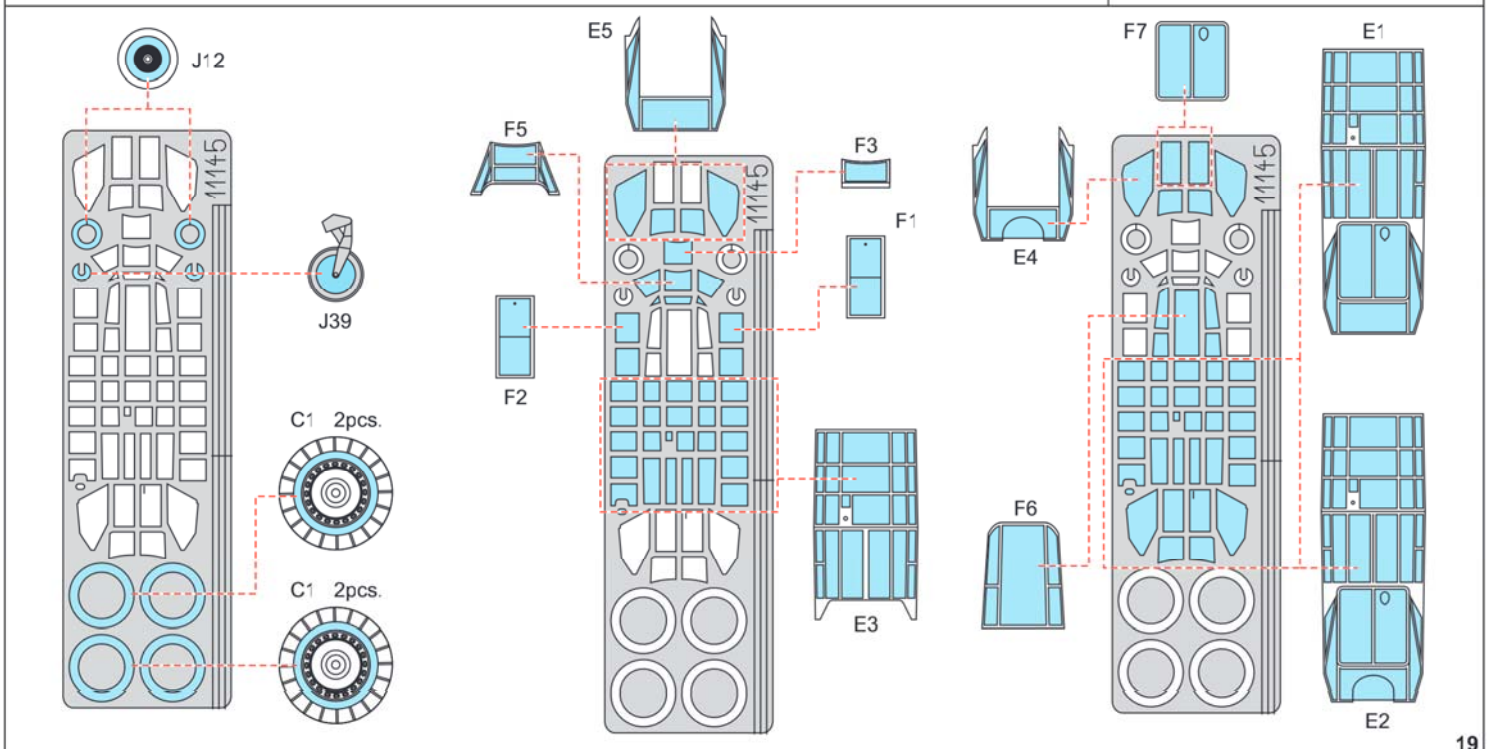
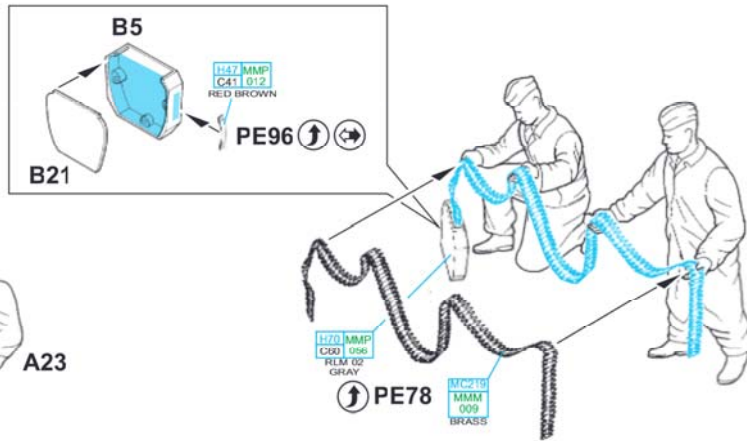
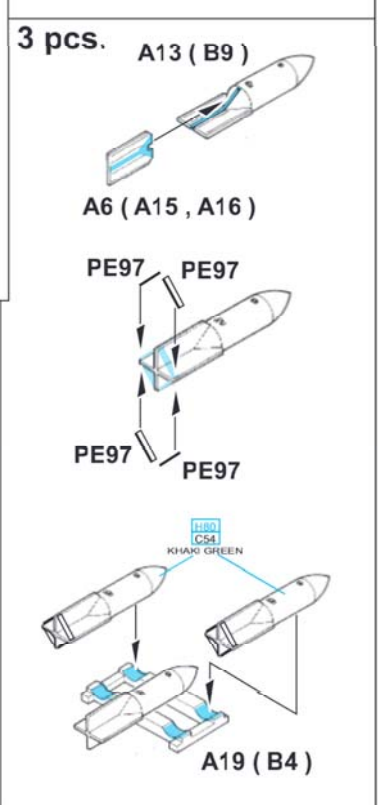
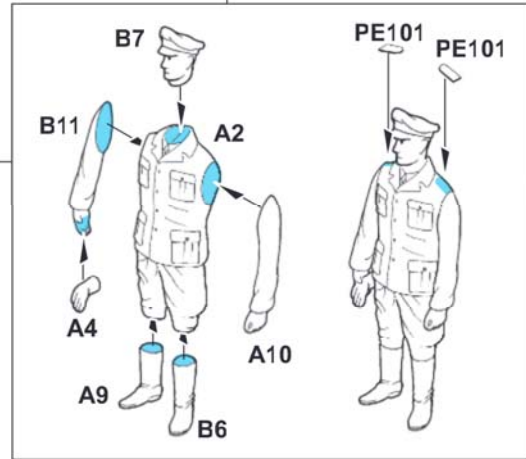
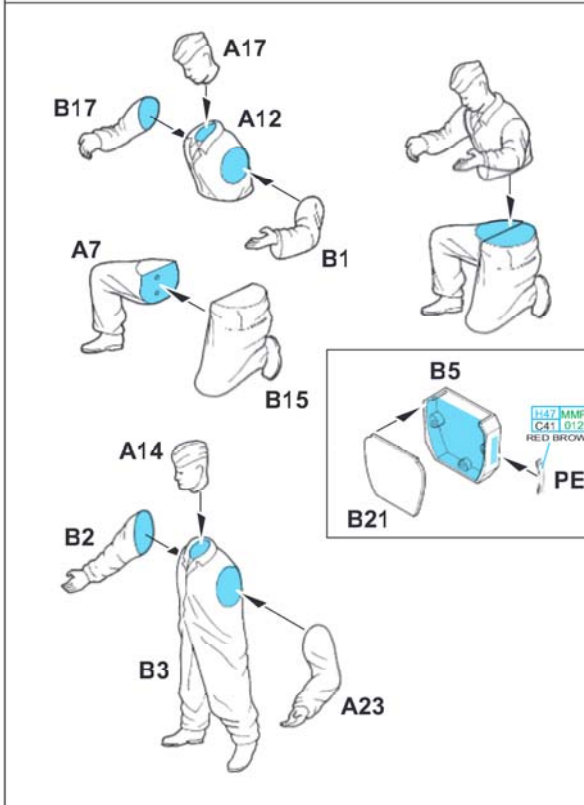
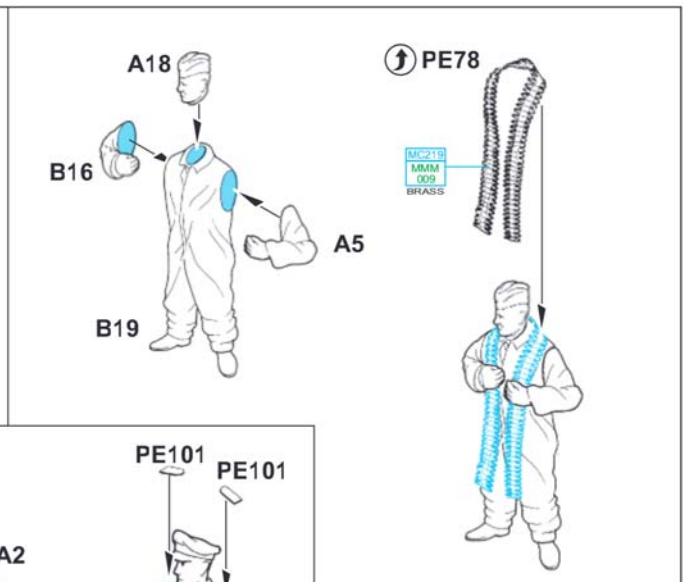
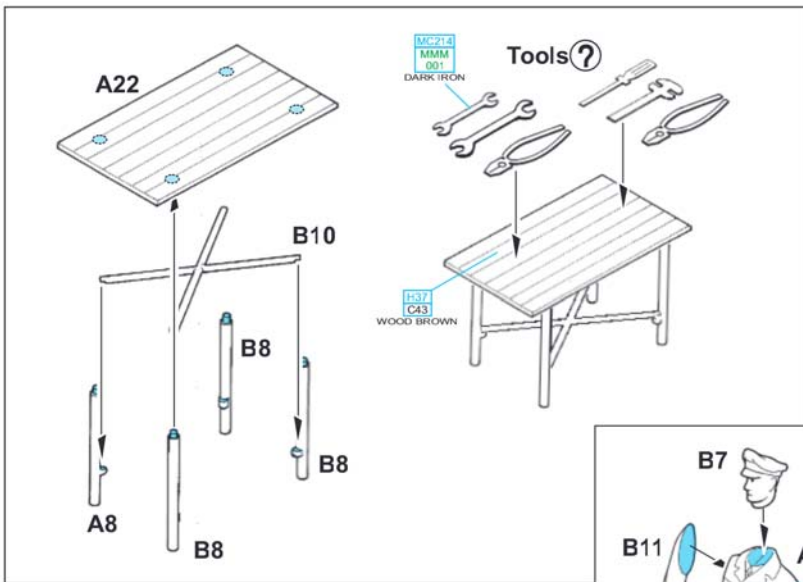

# A Bf 110C flown by Hptm. Horst Liensberger, CO of Stab V.(Z)/LG 1, France, summer 1940

One of three known aircraft flown by Hptm. Liensberger. Camouflage consist of RLM 70, 71 and 65. Originally dark green fuselage sides are overpainted with RLM 65. Individual letter "X" is in green color assigned to Stab aircraft. Wolf's head is emblem of heavy fighter element of LG 1. Horst Liensberger was born in 1909 in Innsbruck, Austria. In 1932 he graduated as Leutnant from Militärakademie in Wiener Neustadt. In first months of war he commanded 2./ZG 52 (2./JGr 152). In mid April 1940 he took over command of V.(Z)/LG 1 and led his men through Battle of France and most of Battle of Britain. It is assumed he scored four victories including one French aircraft. He was killed together with his gunner Uffz. Albert Köpge on September 27th over Simmons Field near Hamllins Mill. After forty miles pursuit, often at treetop height, their aircraft was rammed by Hurricane piloted by F/O Burton of No. 249 Squadron who was also killed.

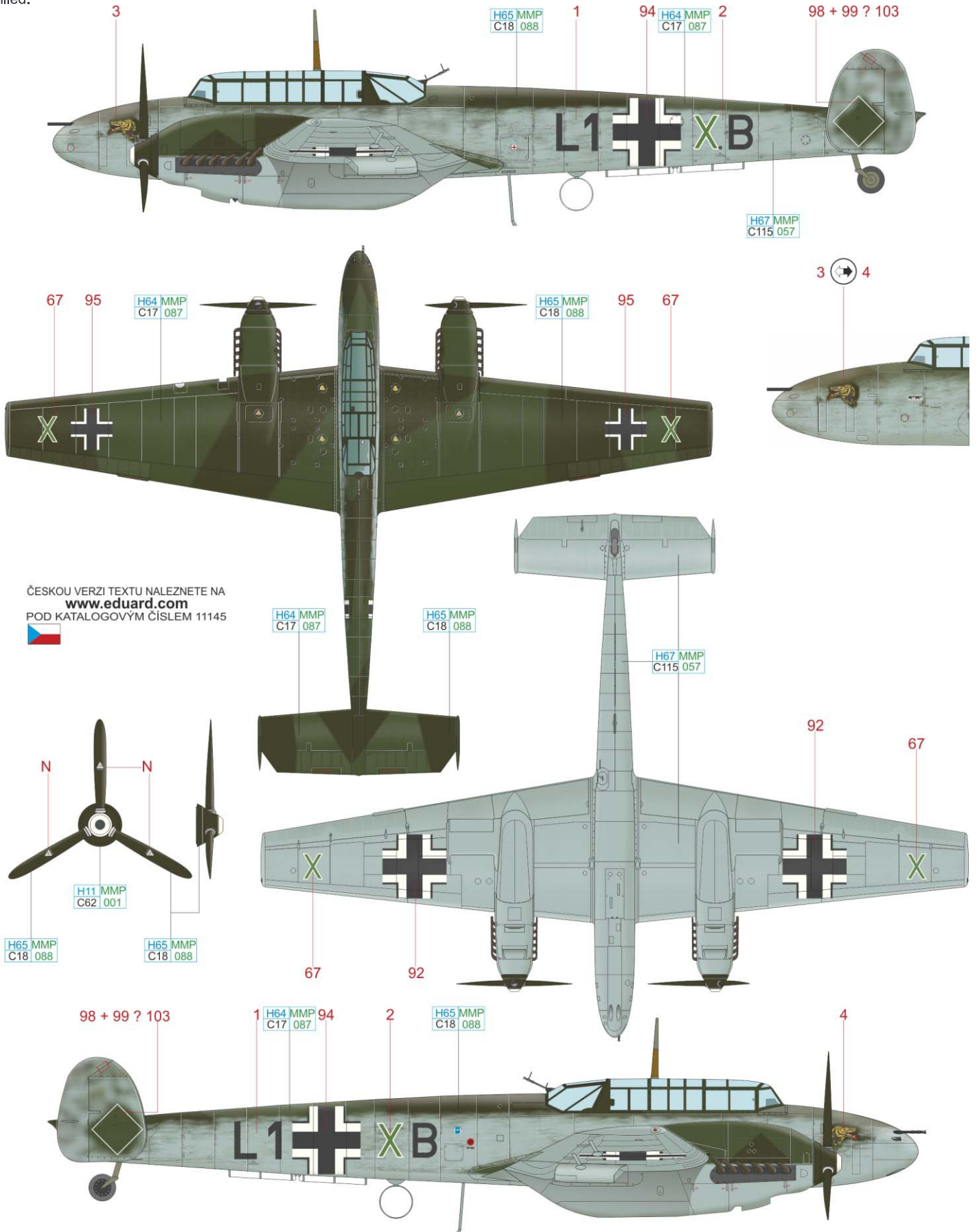

ČESKOU VERZI TEXTU NALEZNETE NA  
[www.eduard.com](http://www.eduard.com)

POD KATALOGOVÝM ČÍSLEM 11145



WHITE	H11 MMP C62 001	RLM 65	H67 MMP C115 057	RLM 70	H65 MMP C18 088	RLM 71	H64 MMP C17 087
-------	-----------------	--------	------------------	--------	-----------------	--------	-----------------

eduard

# B Bf 110C-1, 3./ZG 1, Grieslinen, Germany, September 1939

Example of Bf 110 from beginning of World War 2 with early style of fuselage cross. Camouflage consist of RLM 70, 71 and 65. Lion's head is emblem of I./ZG 1. First commander of the unit was Great War veteran Major Joachim-Friedrich Huth. In February 1940 this position was taken over by legendary Hptm. Wolfgang Falck who led his unit successfully through campaign in Denmark, Norway and France. Falck based on his own initiative started to work on night fighter tactics. In June 1940 the I./ZG 1 was converted to night fighter unit I./NJG 1. Wolfgang Falck became first Kommodore of NJG 1. From September 1939 to October 1940 commander of 3./ZG 1 was Legion Condor veteran Oblt. Walter Ehle. He was born in 1912 in Windhoek (today capital of Namibia) and later became commander of II./NJG 1 awarded with Knight Cross and 39 victories on his tally.

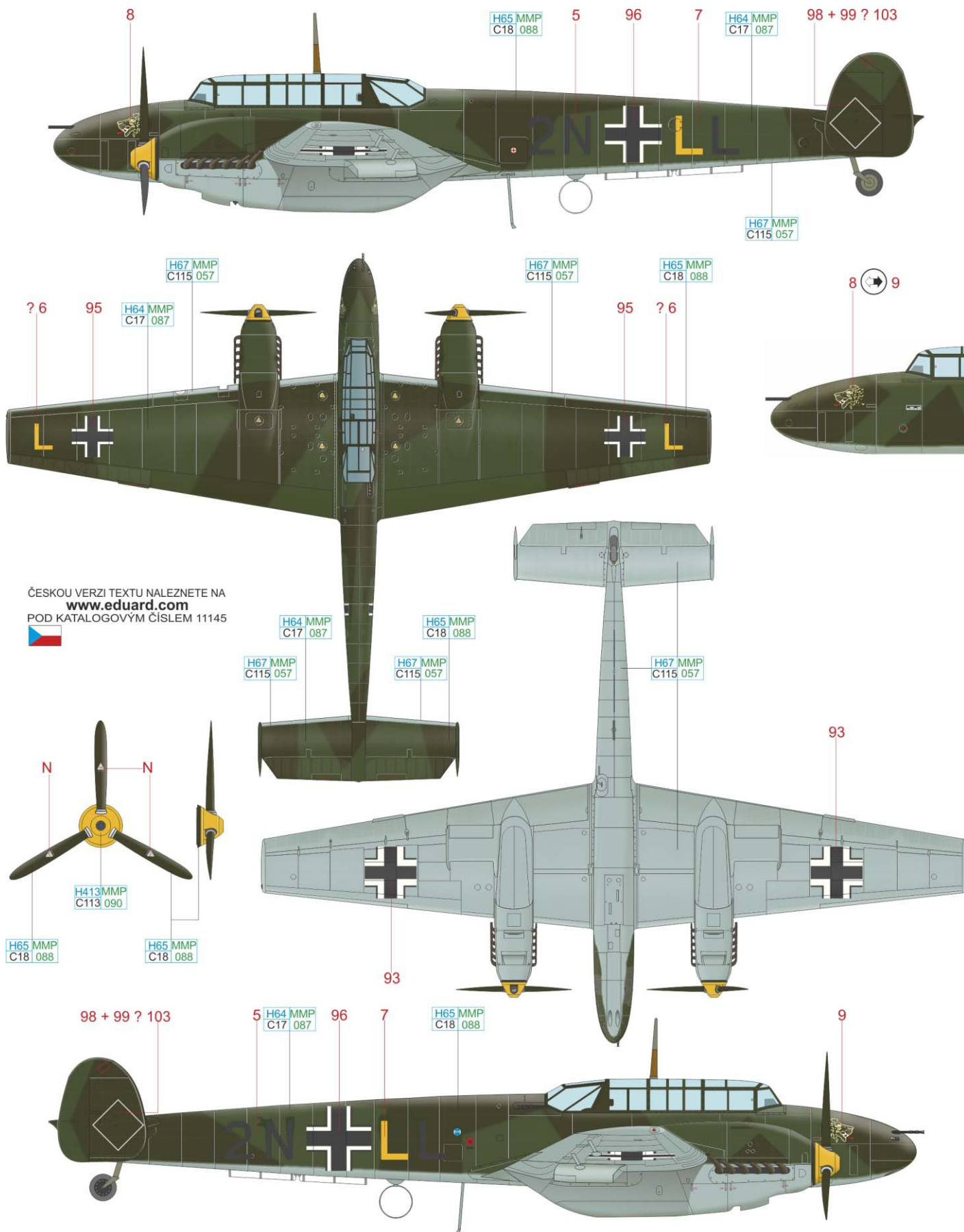

ČESKOU VERZI TEXTU NALEZNETE NA  
**www.eduard.com**  
 POD KATALOGOVÝM ČÍSLEM 11145



- RLM 04 H413MMP C113 090
- RLM 65 H67 MMP C115 057
- RLM 70 H65 MMP C18 088
- RLM 71 H64 MMP C17 087

# C Bf 110D-0, 1./ZG 2, Amiens-Glissy, summer 1940

Camouflage of this Messerschmitt consist of RLM 71, 02 and 65. I./ZG 2 used in first months of war Bf 109C and D and under the command of Hptm. Hannes Gentzen who scored 7 victories during invasion to Poland. From mid 1939 the red hand was symbol of 1. Staffel, Bernburg Hunter (Bernburger Jäger) was symbol of whole I. Gruppe, linking it to Bernburg base where the unit was established in mid 1939. One of founding members of the unit was Erich Groth, who became Kommodore of ZG 76 in 1941. In February 1940 when I./ZG 2 was getting first Bf 110s, commander of 1./ZG 2 was Legion Condor veteran Hptm. Armin Ettling. But in May he came back to 109s and took over command of 7./JG 2 "Richthofen". During Battle of Britain one of 1./ZG 2 commanders Oblt. Gerhard Götz became POW. During bomber escort mission on August 25th his Bf 110C-4 "3M+AH" was shot down by Spitfires of Sergeant A.N. Feary of No. 609 Squadron and Flying Officer P.C. Webb of No. 602 Squadron. Aircraft crashed at Creech Barrow near Wareham. Götz and his gunner Uffz. K. Haupt bailed out. I./ZG 2 was disbanded at the end of September 1940 and 1./ZG 2 was transferred to night fighter duty as 4./NJG 2.

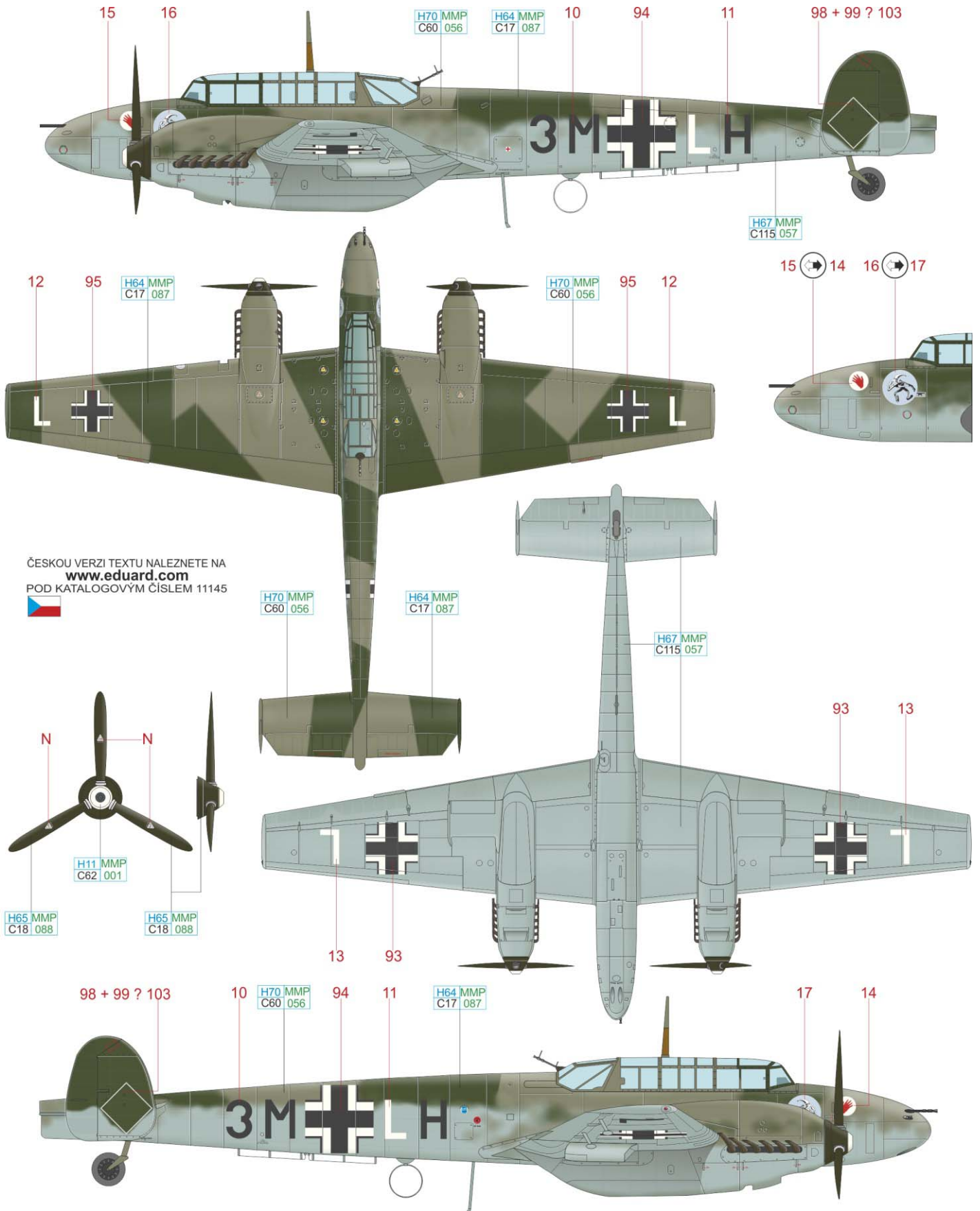

ČESKOU VERZI TEXTU NALEZNETE NA  
[www.eduard.com](http://www.eduard.com)

POD KATALOGOVÝM ČÍSLEM 11145



WHITE	H11 MMP C62 001	RLM 65	H67 MMP C115 057	RLM 02	H70 MMP C60 056	RLM 70	H65 MMP C18 088	RLM 71	H64 MMP C17 087
-------	--------------------	--------	---------------------	--------	--------------------	--------	--------------------	--------	--------------------

# D Bf 110D, WNr. 3181, 4./ZG 2, Freiburg, Germany, July 1940

This is so far only known example of a Bf 110D belonging to II./ZG 2 equipped with additional fuel tank under fuselage, so called "Dackelbauch". II./ZG 2 was renamed in July 1940 from I./ZG 52 and kept its original emblem - white dragon in black shield. II./ZG 2 also kept its original fuselage codes of I./ZG 52. Camouflage consist of RLM 71, 02 and 65. Unit lost its Gruppenkommandeur Major Harry Carl on August 16th after combat with RAF fighters over the Channel. He got killed together with his gunner Uffz. W. Maier in a crash landing near Beauzeville, France. The 4. Staffel commander was Hptm. Hans Peter Külbel, former policeman and pre-war commander of military flying school. On August 11th, 1940 he was appointed temporary commander of I./ZG 2. However on next day he was shot down and killed together with his gunner Uffz. F. Budig by RAF fighters off Portsmouth. His body was washed ashore on September 18th near Boulogne. Due to heavy losses most parts of II./ZG 2 were disbanded in September 1940 including 4./ZG 2.

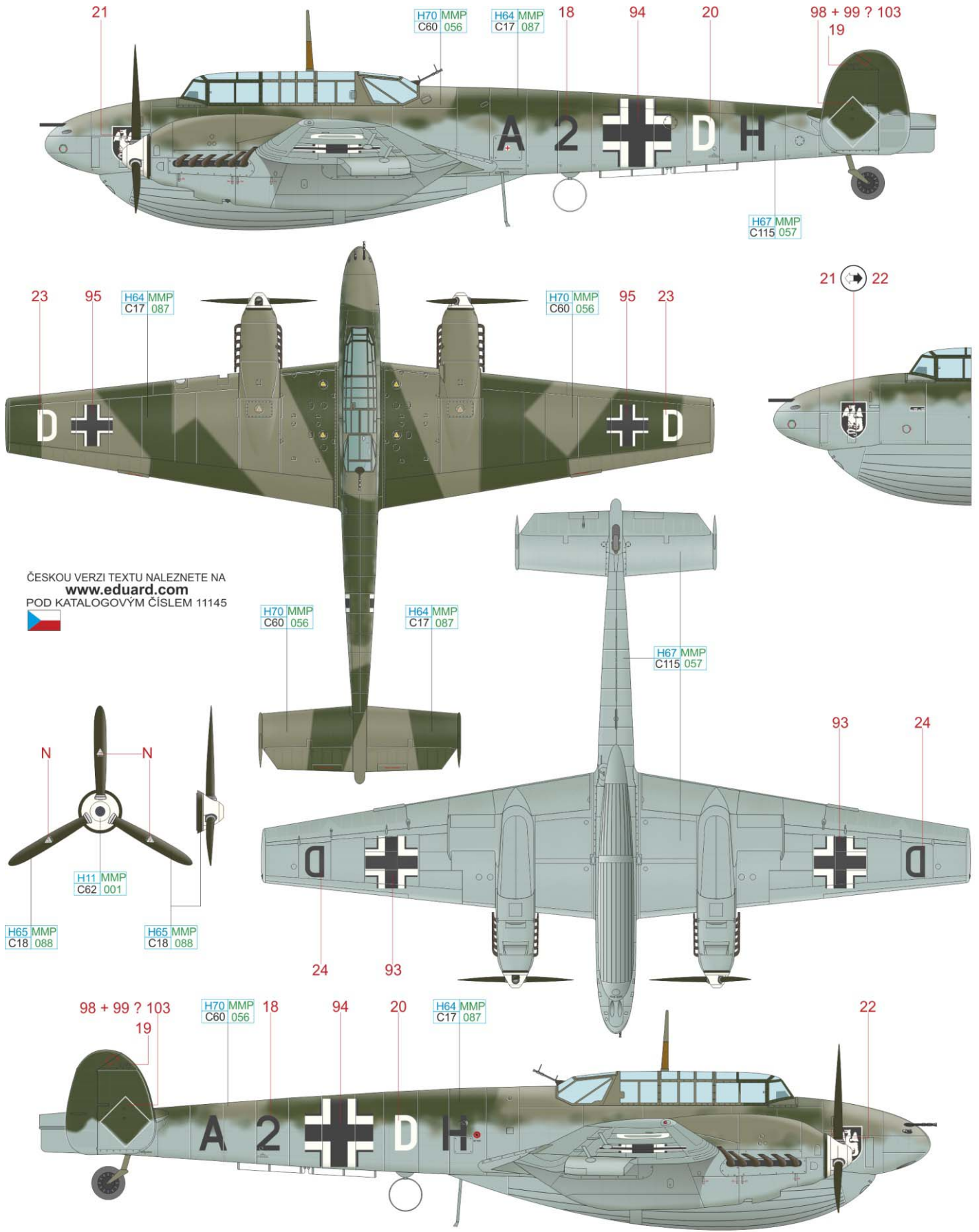

ČESKOU VERZI TEXTU NALEZNETE NA  
[www.eduard.com](http://www.eduard.com)  
 POD KATALOGOVÝM ČÍSLEM 11145



- WHITE
- H11 MMP C62 001
- RLM 65
- H67 MMP C115 057
- RLM 02
- H70 MMP C60 056
- RLM 70
- H65 MMP C18 088
- RLM 71
- H64 MMP C17 087

# E Bf 110C, flown by Obstlt. Joachim-Friedrich Huth, CO of Stab ZG 26, Lille, France, September 1940

Camouflage of this airplane consist of RLM 71, 02 and 65. Nose is overpainted with washable white color brushed over the white chevron. "3U+AA" was personal mount of Obstlt. Huth who led ZG 26 from December 1939 till end of October 1940. He was Great War veteran, born in 1896. After three injuries as infantryman he decided to join German Air Service and joined Jasta 14. He shot down French balloon at the beginning of 1918 which he marked on tail of his Bf 110 two decades later. Huth suffered serious injury in March 1918 in air combat and his right lower leg had to be amputated. He was back in military service in 1919 and in April 1936 became commander of 5./JG 132 "Richthofen". From August 1938 he led II./JG 132 (later I./ZG 1). Huth was awarded with Knight Cross in September 1940 based on successes of ZG 26. Later in the war he commanded Jafü 2, 1. Jagddivision, 7. Jagddivision and I. Jagdkorps. After the war he was held by British as POW at Island Farm Special Camp. Huth joined Bundesluftwaffe in 1956 and retired in 1961 as Generalleutnant and commander of Luftwaffe Group South. He passed away in 1962.

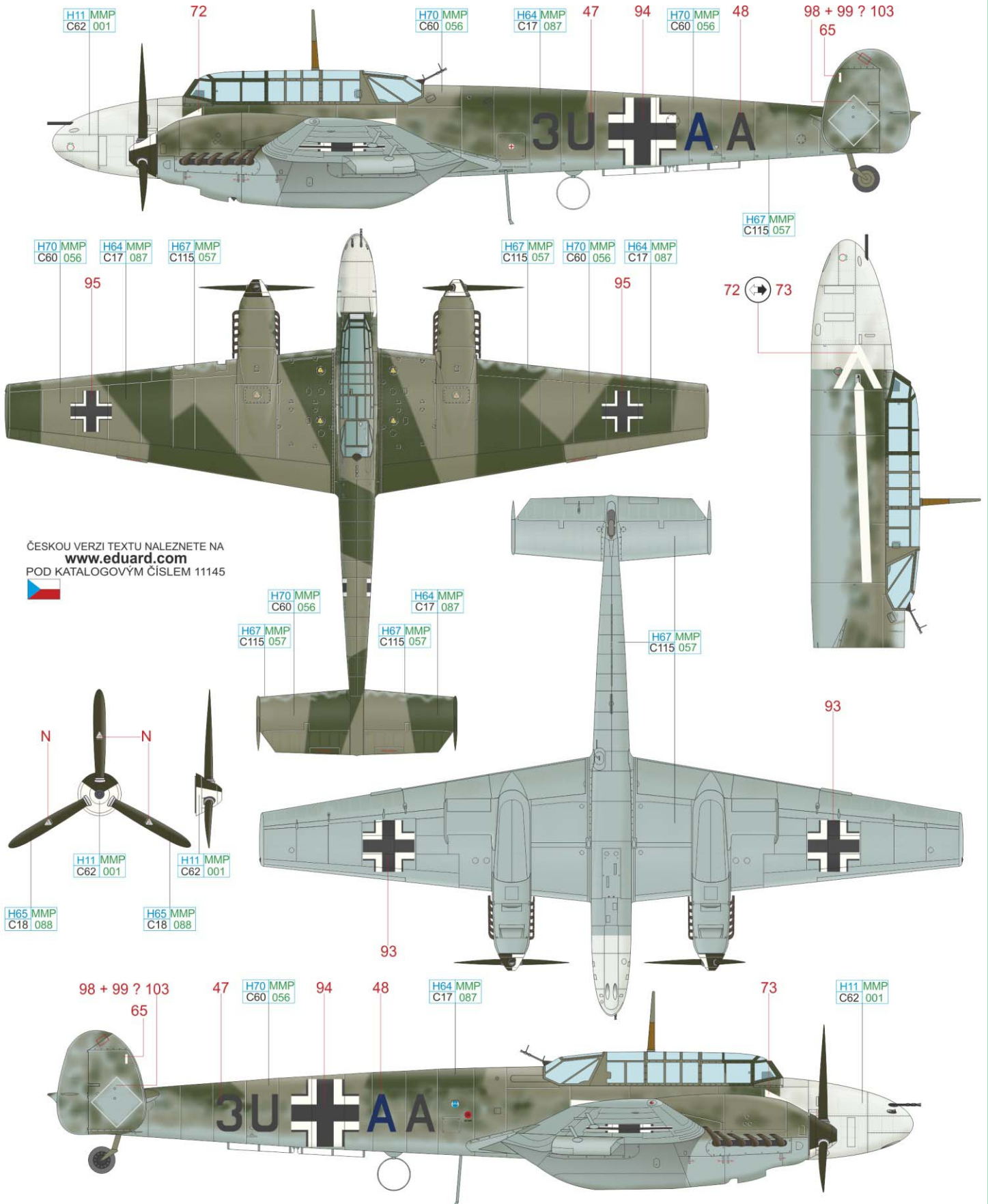

ČESKOU VERZI TEXTU NALEZNETE NA  
[www.eduard.com](http://www.eduard.com)  
 POD KATALOGOVÝM ČÍSLEM 11145



WHITE	H11 MMP C62 001	RLM 65	H67 MMP C115 057	RLM 02	H70 MMP C60 056	RLM 70	H65 MMP C18 088	RLM 71	H64 MMP C17 087
-------	-----------------	--------	------------------	--------	-----------------	--------	-----------------	--------	-----------------

# F Bf 110D-0, WNr. 3716, 2./ZG 26, Yvrench/St. Omer, France, August 1940

This Bf 110 was damaged on August 18th, 1940 by Hurricanes of No. 56 Squadron over Thames. Enroute to homebase the crew tried to land on another airfield and overturned their machine. Both crewmen were unhurt, but their Bf 110 was damaged beyond repair. The emblem of I./ZG 26 called "Ringelpitz" features red German crocodile hunting a black British flying fish. Small rear fuselage band was marking of this unit in later stage of Battle of Britain. Camouflage consist of RLM 71, 02 and 65. At beginning of the war I./ZG 26 was equipped with Bf 109 C and D, under command of Austrian Hptm. Karl Kaschka. After conversion to Bf 110 this unit was led by Hptm. Wilhelm Makrocki, who obtained Knight Cross in October 1940. From May 1940 Staffelkapitän of 2./ZG 26 was Hptm. Herbert Kaminski. He and his gunner Uffz. H. Strauch was shot down and wounded on August 18th as well. They ditched the Channel off Dunkerque and were rescued four days later. Kaminski later commanded various Bf 110 and 109 units, namely I./ZG 26 in Russia, I./JG 53 in Holland and II./ZG 76 in Defence of the Reich. Knight Cross holder Kaminski flew 300 sorties and scored 7 victories.

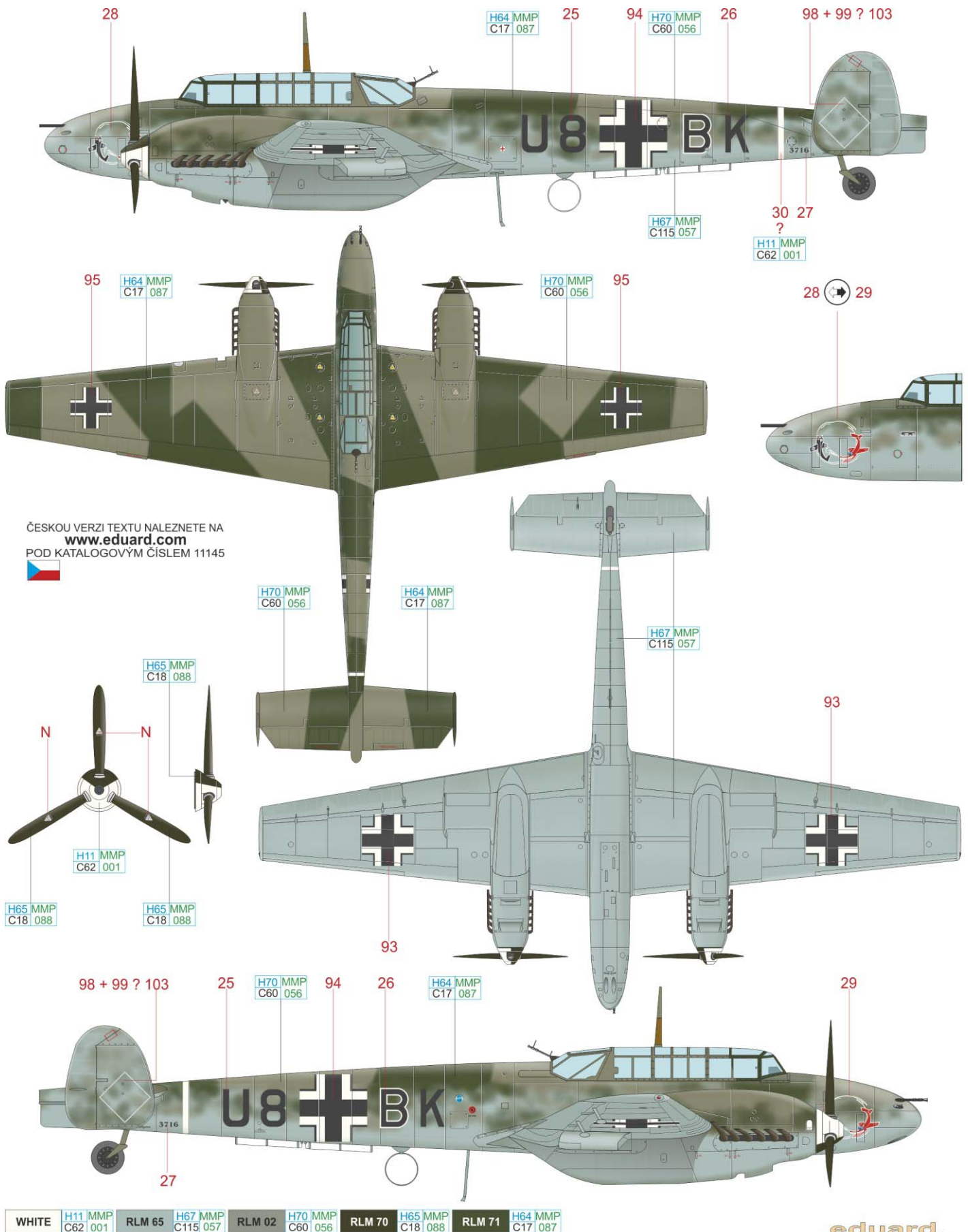

# G Bf 110D, 4./ZG 26, Crecy-en-Ponthieu, France, September 1940

This Bf 110D was equipped with DB 601N engines. Wooden shoe was marking of II./ZG 26 from 1940 to 1944. Lady bird was emblem of 4./ZG 26, but was also by III./ZG 26. Camouflage consist of RLM 71, 02 and 65. White paint on the nose identifies the aircraft as ship assigned from September 1940 to fighter bomber missions or their escort. At beginning of the war II./ZG 26 was equipped with Bf 109D, under command of Great War fighter veteran Major Friedrich Vollbracht. His unit converted to Bf 110 during October 1939 and he handed over command in April 1940 to Hptm. Ralph von Rettberg (8 victories, Knight Cross) who held his position till April 1942. Staffelkapitän of 4./ZG 26 Hptm. Hubert Lüttke and his gunner Uffz. H. Brillio were shot down on August 18th, 1940 by Spitfire ace F/O Colin Falkland Gray of No. 54 Squadron. His successor Oblt. Arthur Niebuhr and his gunner Uffz. K. Theissen were killed on September 27th by RAF fighters near Arne. Staffel was finally taken over by Hptm. Reinhold Hubel who served with II./ZG 26 and III./ZG 1 in Mediterranean till 1943.

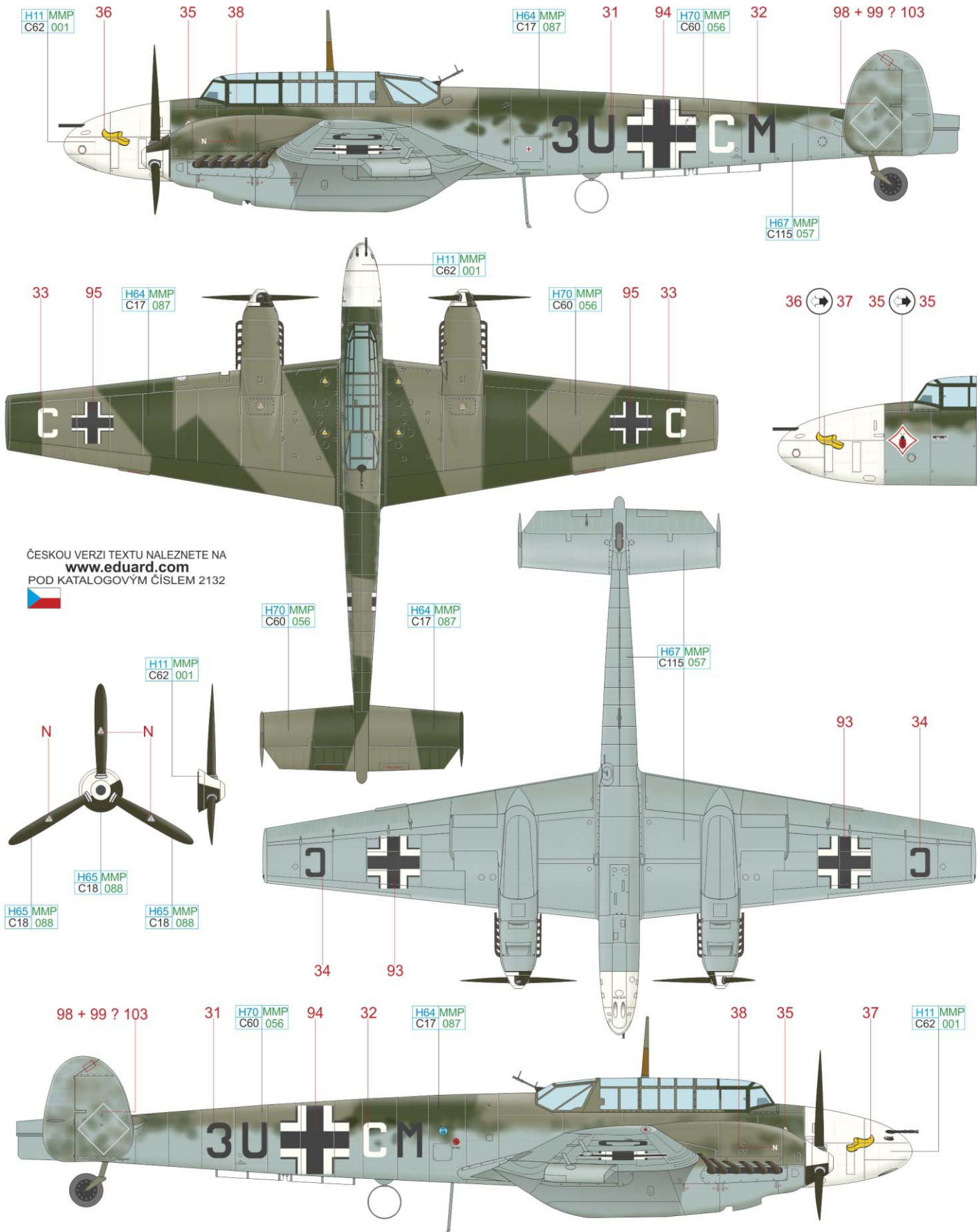

ČESKOU VERZI TEXTU NALEZNETE NA  
[www.eduard.com](http://www.eduard.com)  
 POD KATALOGOVÝM ČÍSLEM 2132



- WHITE
- H11 MMP C62 001
- RLM 65
- H67 MMP C115 057
- RLM 02
- H70 MMP C60 056
- RLM 70
- H65 MMP C18 088
- RLM 71
- H64 MMP C17 087

# H Bf 110C, flown by Oblt. Sophus Baagoe, 8./ZG 26, Barley-Arques, France, July 1940

Also this Zerstörergruppe was equipped with Bf 109D type at beginning of the war. III./ZG 26 converted to Bf 110 in early 1940 under command of Hptm. Johannes Schalk who led Austrian Jagdgruppe 1 before the war. He was also one of first Bf 110 pilots to obtain Knight Cross. Commander of 8./ZG 26 during attack against France and Battle of Britain was Hptm. Karl-Heinz "Conny" Meyer who later led also II./JG 26. One of his most successful pilots was Sophus Baagoe. He scored four victories over France, three during Kanalkampf and six during Battle of Britain. Camouflage of his airplane consist of RLM 70, 71 and 65. Crosses on upper surfaces are sized down and camouflage seems to be slightly oversprayed, probably with RLM 02. Early version of 8. Staffel emblem the "sad fox" was probably painted on fuselage. In spring 1941 Baagoe was transferred to 5./ZG 26. He is one of pilots who may have shot down on April 20th over Greece the top RAF ace Squadron Leader "Pat" Pattle of No. 80 Squadron. Baagoe was killed by ground fire on May 14th, 1941 during strafing attack against Heraklion airfield, Crete.

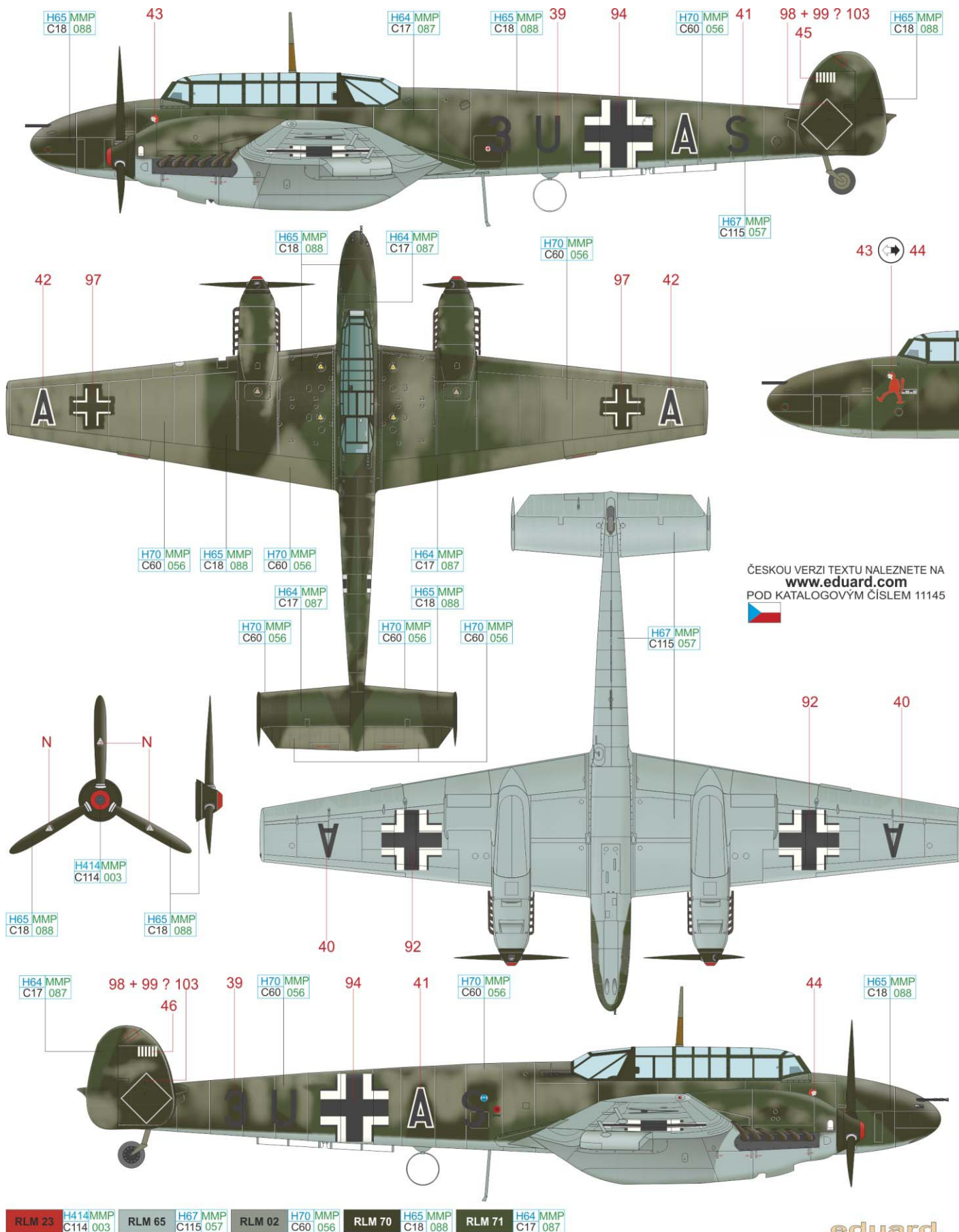

ČESKOU VERZI TEXTU NALEZNETE NA  
[www.eduard.com](http://www.eduard.com)  
 POD KATALOGOVÝM ČÍSLEM 11145



RLM 23 H414 MMP C114 003 RLM 65 H67 MMP C115 057 RLM 02 H70 MMP C60 056 RLM 70 H65 MMP C18 088 RLM 71 H64 MMP C17 087

eduard

# Bf 110C, WNr. 3285, flown by Oblt. Hans-Joachim Jabs, CO of 6./ZG 76, Le Mans, France, September 1940

Hans-Joachim Jabs was highest scoring Bf 110 ace in Battle of Britain achieving 12 victories in addition to 7 scored earlier during Battle of France. His preferred combat method was hit and run attack from above. Camouflage of his Bf 110 consist of RLM 70, 71 and 65. Sharkmouth (Haifischmaul) was marking of II./ZG 76 since pre-war period when this unit was using Bf 109D. Commander of 6./ZG 76 for period of more than one year was Legion Condor veteran Hptm. Heinz Nacke (12 victories, awarded with Knight Cross). He was injured in combat with RAF fighters on August 30th and Jabs was placed as temporary commander of 6. Staffel followed by permanent appointment in October 1940. During same month Jabs was also decorated with Knight Cross. In late 1941 his Staffel was trained for night fighter operations and was renamed as 9./NJG 3. He later led also 11./NJG 1 and IV./NJG 1. In March 1944 he became Kommodore of whole Nachtjagdgeschwader 1 and received Oak Leaves in addition to Knight Cross. Jabs scored 50 victories in 510 missions.

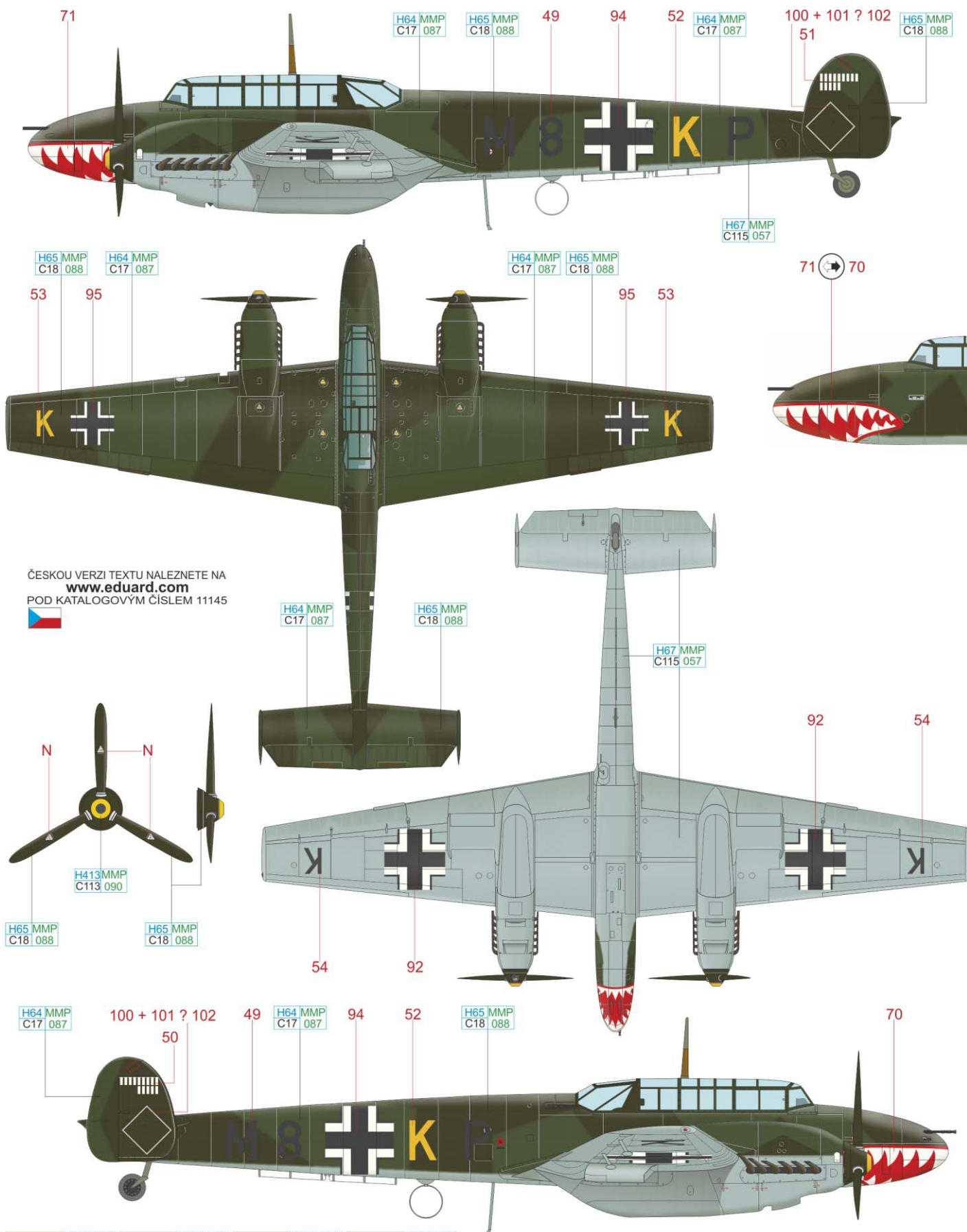

ČESKOU VERZI TEXTU NALEZNETE NA  
[www.eduard.com](http://www.eduard.com)  
 POD KATALOGOVÝM ČÍSLEM 11145



# J Bf 110D-0, 7./ZG 76, Laval, France, October 1940

In June 1940 heavy fighter unit II./ZG 1 was redesignated as III./ZG 76 and kept also original emblem three wasps above a cloud. Camouflage of this airplane consist of RLM 71, 02 and 65. From early 1940 commander of this Zerstörergruppe was Hptm. Friedrich-Karl Dickoré and he continued to lead his unit under III./ZG 76 designation. On August 15th over the Channel off Weymouth he collided with another airplane during dogfight with Hurricanes of No. 213 Squadron. His gunner Uffz. H. Templin was captured, but Dickoré did not survive and his body washed ashore dead at Le Touquet on September 20th. From beginning of 1940 commander of 4./ZG 1 (later 7./ZG 76) was Legion Condor veteran Oblt. Rolf "Schlitzohr" Kaldrack. He scored three victories in Spain as reconnaissance pilot. In spring 1940 he also shot down one Swiss Bf 109. Kaldrack took over command of III./ZG 76 after death of Dickoré. He was awarded with Knight Cross in November 1940 after achieving 11 victories since outbreak of war. He was killed in February 1942 on Eastern front and received Oak Leaves posthumously.

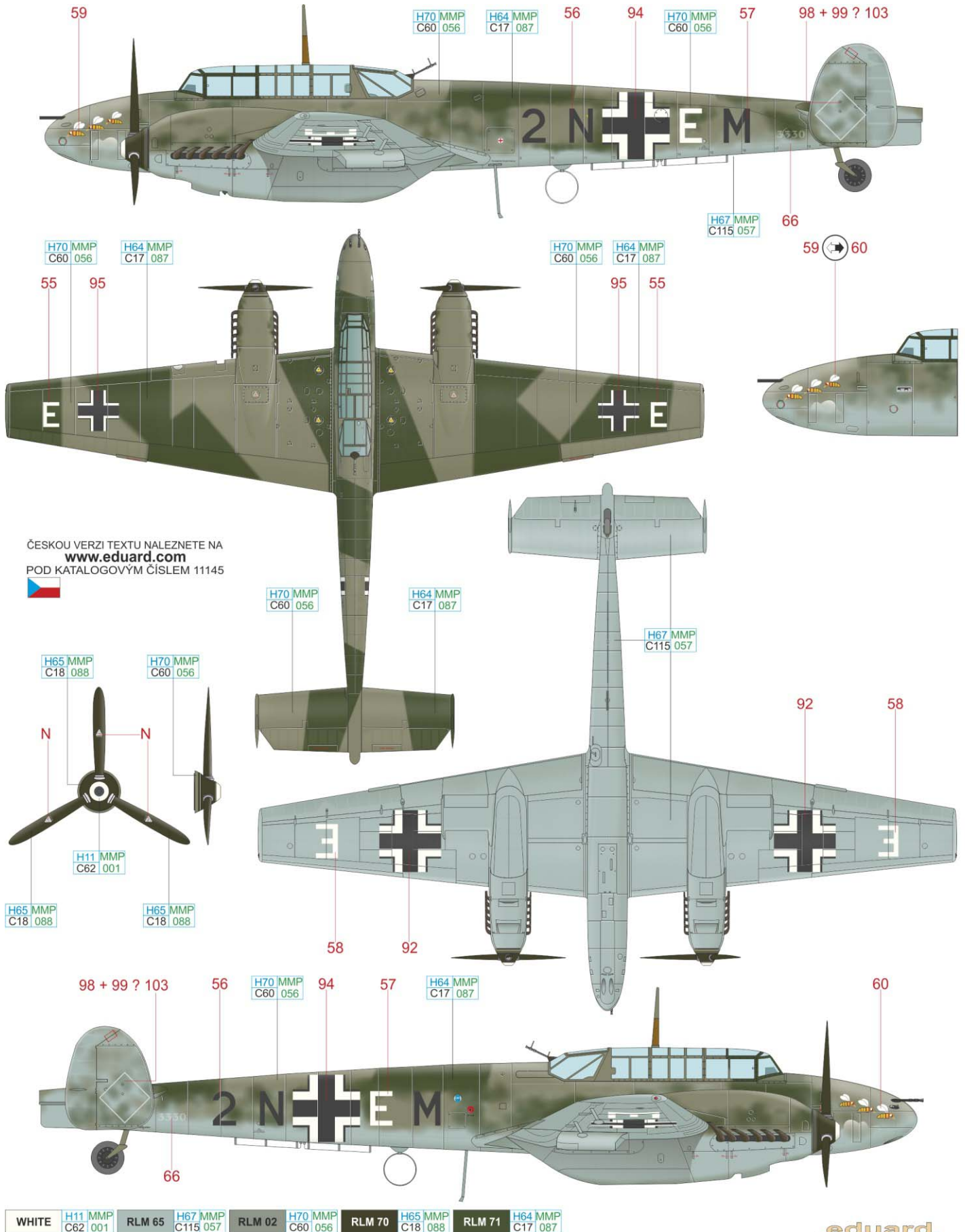

ČESKOU VERZI TEXTU NALEZNETE NA  
**www.eduard.com**  
 POD KATALOGOVÝM ČÍSLEM 11145

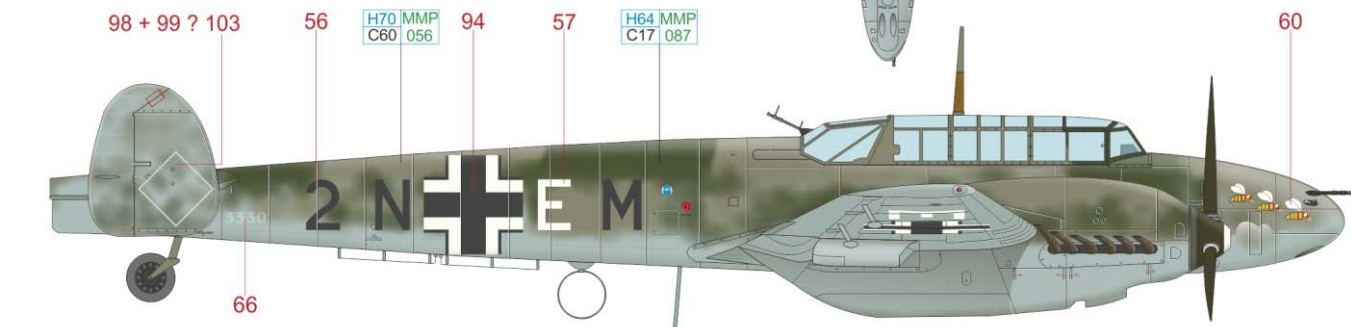
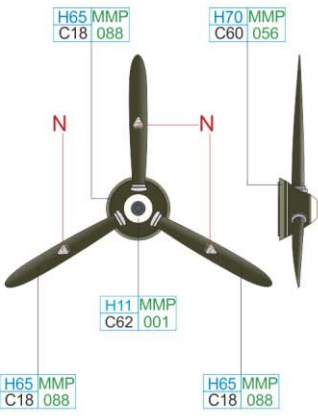

- WHITE
- H11 MMP C62 001
- RLM 65
- H67 MMP C115 057
- RLM 02
- H70 MMP C60 056
- RLM 70
- H65 MMP C18 088
- RLM 71
- H64 MMP C17 087

# K Bf 110D-3, WNr. 3378, flown by Oblt. Martin Lutz, CO of Erprobungsgruppe 210, Calais-Marck, France, September 1940

Erprobungsgruppe 210 (Test Wing 210) was formed in July 1940 under the command of Hptm. Walter Rubensdörffer as unit for operations against United Kingdom. Initially it was supposed to test in combat Messerschmitt Me 210, the intended successor to Bf 110. But new type was delayed and instead Erp. Gr. 210 got task to develop fighter bomber concept with Bf 110 and Bf 109. Unit performed very well against military and industrial targets, but sustained also heavy losses, including four commanders of Gruppe. One of them was Legion Condor veteran Hptm. Martin Lutz, previously Staffelkapitän of 1./Erp. Gr. 210 (former 1./ZG 1). He scored one victory in Spain and later on fought in Poland and France. On September 27th during raid against Parnall aircraft factory near Bristol he was shot down in and killed in "S9+DH" by Hurricanes of No. 504 Squadron. Lutz was awarded with Knight Cross posthumously. Camouflage of his airplane consist of RLM 71, 02 and 65. Blue color of letter "D" was common practice of 1./Erp. Gr. 210.

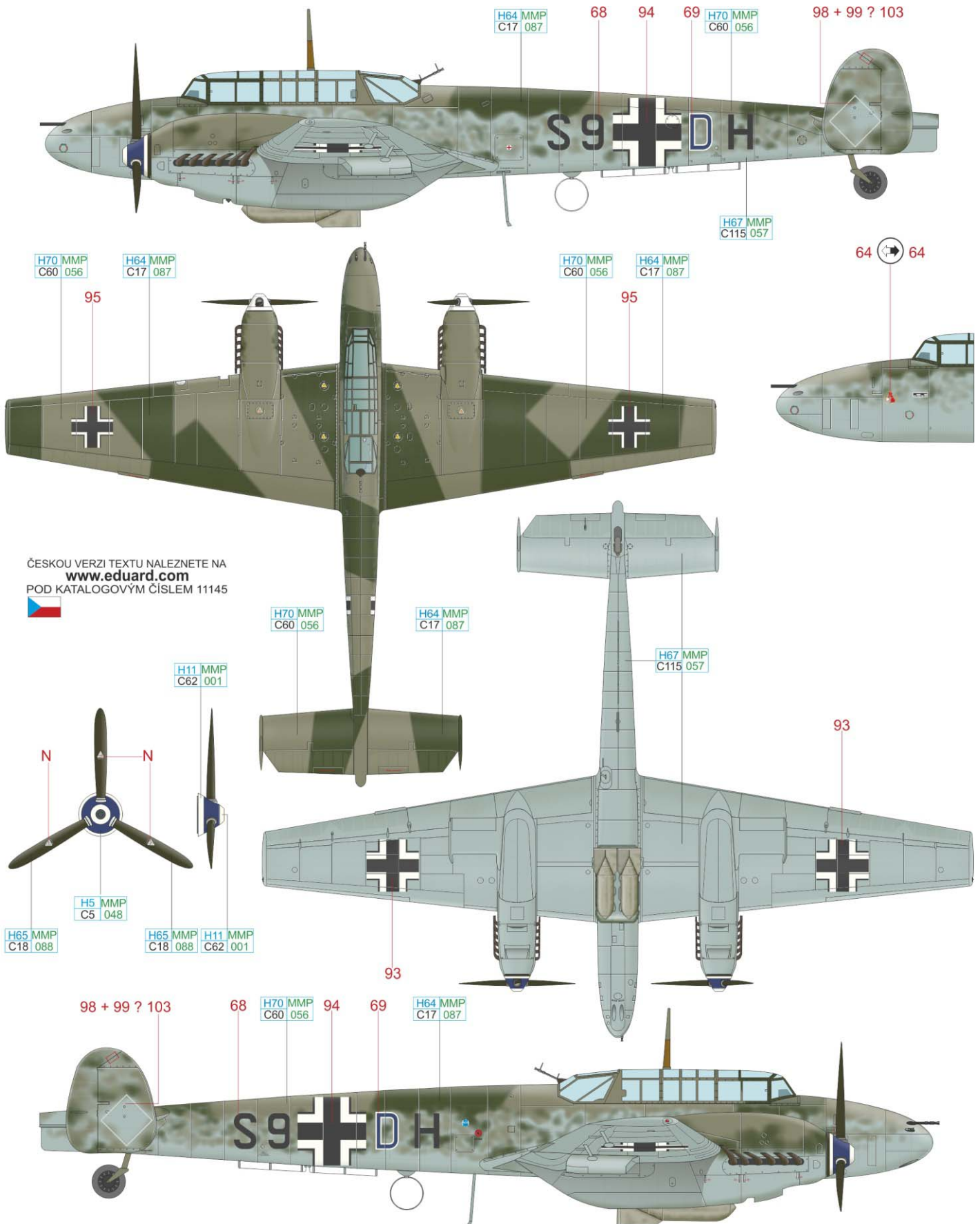

WHITE	H11 MMP C62 001	BLUE	H5 MMP C5 048	RLM 65	H67 MMP C115 057	RLM 02	H70 MMP C60 056	RLM 70	H65 MMP C18 088	RLM 71	H64 MMP C17 087
-------	-----------------	------	---------------	--------	------------------	--------	-----------------	--------	-----------------	--------	-----------------

# Bf 110C-6, flown by Lt. Erich Beudel, 1./Erprobungsgruppe 210, Calais-Marck, France, August 1940

This rare version of Bf 110 was equipped with 30mm cannon MG 101 under the fuselage. Operational tests started with 1./ZG 1 during Battle of France by Viktor Mölders (brother of Werner Mölders) and Martin Lutz. Weapon was used mainly against ground targets. Later on tests continued when 1./ZG 1 became 1./ Erp. Gr. 210. This particular aircraft was camouflaged with colors RLM 70, 71 and 65. Emblem of United Kingdom in gunsight was used by whole Gruppe. Non-standard blue color of 1. Staffel was used for letter "R" and propeller spinners. There were six C-6s assigned to 1./ Erp. Gr. 210 from July 1940. Their role was also escort of unit's fighter bombers. C-6 flight characteristics were pretty good thanks to changed center of gravity. "S9+RH" was flown on July 29th by Vienna native Lt. Erich Beudel during escort mission over the Channel. His plane was damaged by Hurricanes of No. 151 Squadron and he crash landed back in France. On August 15th, 1940 Lt. Beudel was shot down and killed by Hurricanes of No. 111 Squadron near Horley together with his gunner Ogefr. O. Jordan in their Bf 110C-6 "S9+TH". It was only C-6 crashed in UK.

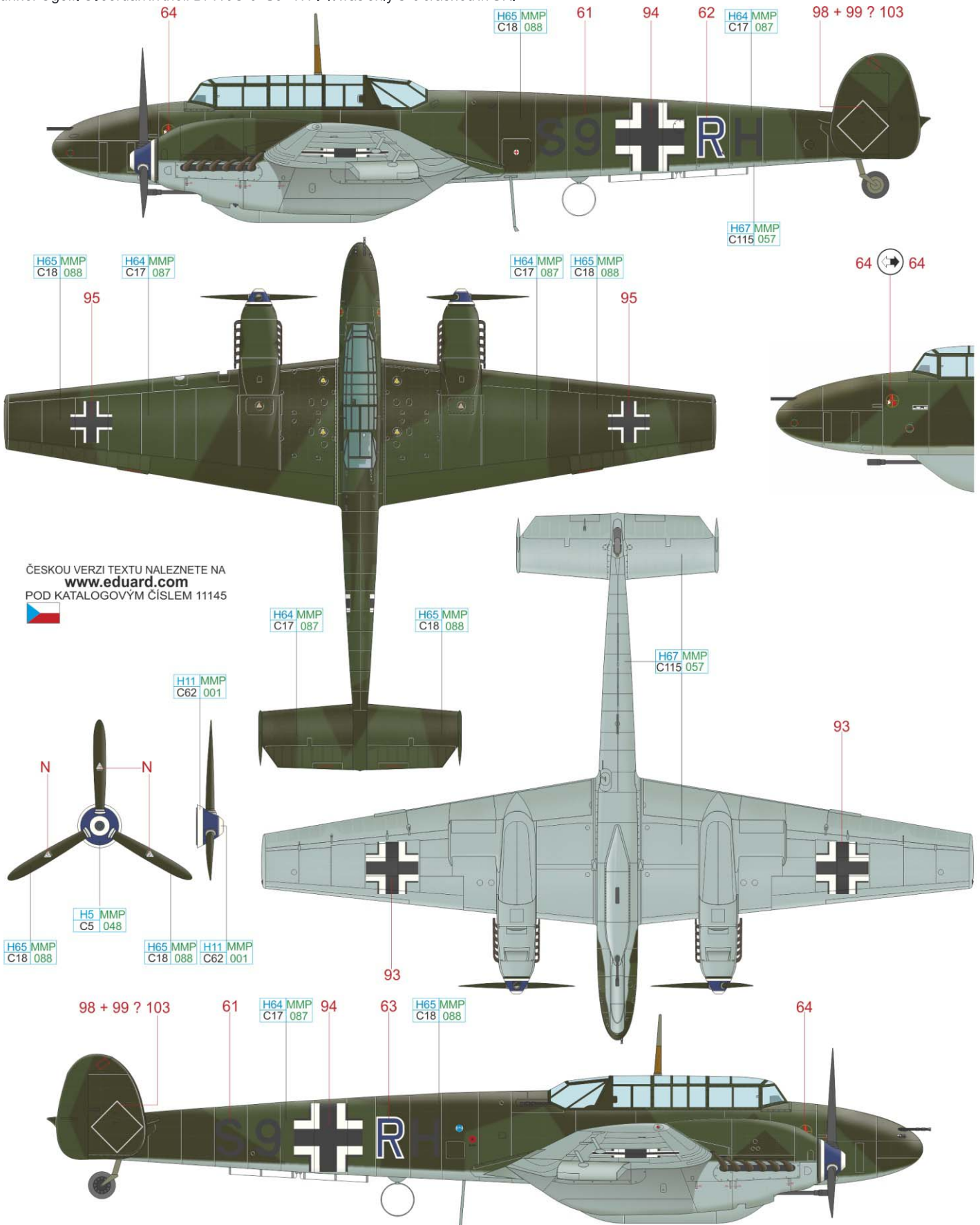

ČESKOU VERZI TEXTU NALEZNETE NA  
[www.eduard.com](http://www.eduard.com)  
 POD KATALOGOVÝM ČÍSLEM 11145



- WHITE H11 MMP C62 001
- BLUE H5 MMP C5 048
- RLM 65 H67 MMP C115 057
- RLM 70 H65 MMP C18 088
- RLM 71 H64 MMP C17 087

